



## Revolutionary metering management in Romania

In 2002 Landis+Gyr was awarded a contract by the European Bank of Reconstruction and Development (EBRD). The EBRD was financing a metering system for the wholesale electricity market in Romania.

The project aim was to modernize all metering facilities of the transmission network in Romania. The meter management system was delivered and installed

by Landis+Gyr at Transelectrica's headquarters in Bucharest. It has been in operation since the end of 2005. It has been operated in full extent till now.

The project has been and continues to be a success since implementation was completed. Due to rapid changes brought about by the liberalization of the electricity market in Romania, an extensive system upgrade was made in the first half of 2006. All the systems work exactly as the customer wanted them to, delivering what they required.

### Benefits and functionality of the metering system

One of the most important components of a liberalized electricity market is an extensive commercial metering system. The system provides metering data to determine energy/power flows including power losses created by contracts between different market participants. It also simulates input from these contracts regarding processing of metering data, which is input information for settlement of contracts between market participants.

Energy transfers result from commercial contracts between market participants; although these flows are not necessarily congruent with physical energy flows in the electrical network system.

The system covers the following tasks but is not limited to:

- Measurement of active and reactive energy, at the border of the transmission network
- Measurement and evaluation of exchanges on the interconnection links with neighbor-systems-Exchanges between market participants
- Evaluation of exchanges between market participants
- Evaluation of losses in the transmission network including calculation of losses of each market participant
- Evaluation of consumption of the auxiliary services within transmission substations and per participant
- Evaluation of exchanges between transmission subsidiaries
- Processing of advanced data aggregation taking into account network parameters
- Data handling for estimation of future power consumption
- Others

### Converge System from Landis+Gyr

Transelectrica chose the Converge and www100 System from Landis+Gyr for the new metering management system. Converge software was designed for data acquisition as well as data processing of electricity meter data that can be either billing values, load profiles or



spontaneous events.

### System architecture

The Management Metering Data System runs on a cluster solution of MS Windows 2000 Advanced Server. The software applications have been built in redundancy.

There are two separate clusters running the Converge application and the database that are configured as two application failover clusters, whereas the www100 system is configured as network load balancing in active/passive mode.

The Converge data acquisition and data processing modules have the following functions:

- Acquiring the meter data either through GSM, Micro Wave or Optic Fibre on a twice-daily basis. The reading of the meters is triggered by a user-defined time schedule. Parallel reading of meter devices are implemented and depend on the number of available modems. Reading of the meters that are connected to the GSM Network are acquired by a GSM Modem pool. No dedicated modem is assigned to the meter. Converge allocates the modem at every reading. Therefore a modem failure will not prevent reading the meters. The meters connected to Micro wave and Fibre Optic each have a dedicated serial connection. Up to 50 meters or even more can be read in parallel. This has the advantage that the meters can be acquired as soon as new values are available in the meters without any transmission costs and that the data retrieved is available in the Converge database within a few seconds after acquisition.
- File import from other systems and file export to other systems are handled on these servers. Meter data is not only acquired from physical meters but also imported from XML formatted files on a daily basis. After a plausibility check and best value calculation, predefined meter data is exported in XML formatted files to other systems through the intranet. Predefined meter data is sent to the www100 system. The enhancement of the system was made in order to implement a user friendly GUI that enables to import XML data files from small meter reading systems that are installed in various locations all over Romania which send their data as attachments via e-mail to

Bucharest.

- As soon as the acquisition process is complete verification starts automatically. Verification is a user defined module which checks meter data for missing values, min-max values and tolerances. After completing these checks the LAN Connection RS232 Connections Fibre optic de-militarised zone Internet Intranet SCSI load profile is exported to defined destinations.

All components are mounted in two cabinets, which are located in two different rooms. The following drawing shows the principal architecture of the system. The colors of the arrows have the following meaning:

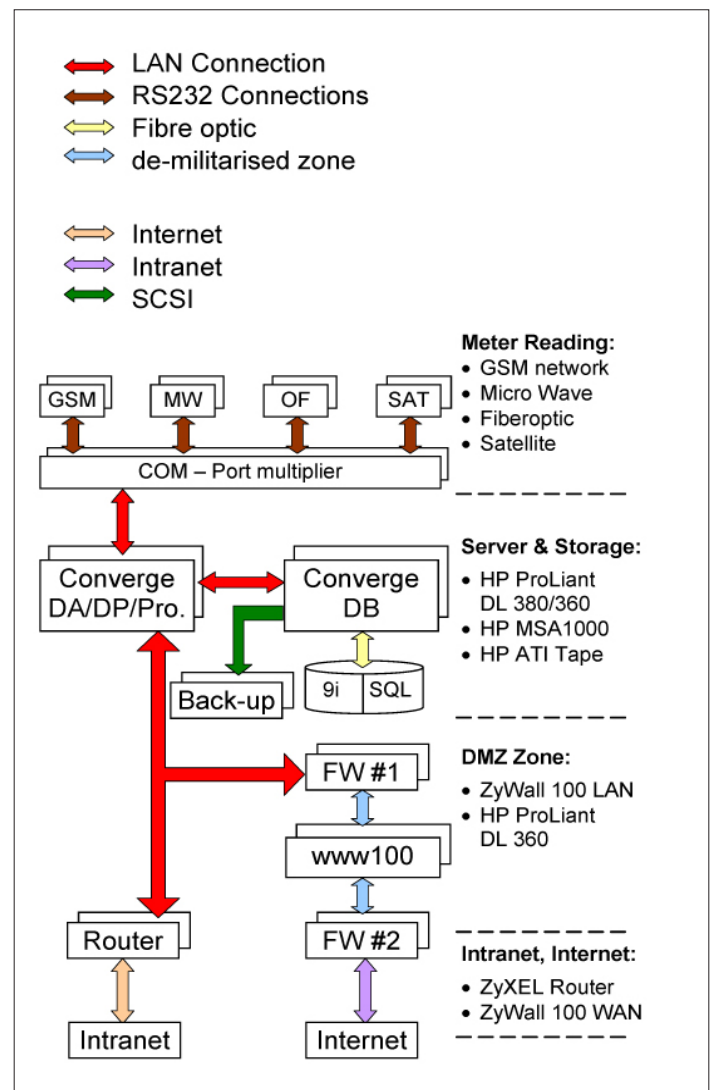

### DA (Data acquisitions module) - meter reading

User definable load profiles, meters, concentrators, frequency of acquiring meter data.



Automatic calculation of the start and end reading pointer of each concentrator which means that all data is acquired regardless of reading interruptions due to mobile phone provider errors.

- 140 concentrators with a total of 900 meters
- SCTM / dlms protocol
- 4000 load profile, integration period 15 minutes
- 250 COM-Ports (RS-232)
- Load profile reading of:
  - Active Energy +
  - Active Energy -
  - Reactive Energy +
  - Reactive Energy -
  - Transmission Energy 'OFF' load losses
  - Transmission Energy 'ON' load losses
  - Event buffer

#### **DP (Data processing) module**

User definable data validation of each meter: This includes missing data, min-max and tolerance check.

Comprehensive best value calculation: This function has been specially developed for this project and calculates the best value of up to eight different meter sources. One meter point – defined as the place where energy is measured – can have multiple meter data sources and one of these sources serves as the best value. The user can freely allocate sources to any meter point; therefore meter changes can be easily handled. The start of the best value calculation is defined in the scheduler.

The redundant meter calculation determines the data of a virtual meter from data of physical meters. This module is useful for metering points that have no physical meters installed. For example, a substation that has no meter on the incoming feeder but meters on all outgoing feeders. The meter data of the incoming feeder will be the sum of all load profiles of all outgoing feeders. The redundant meter calculation is done within the data processing

module and the result will be copied into a predefined virtual meter in the data acquisition module.

#### **Parameters:**

- 1'500'000 values with data checks per day
- 1'600 best value calculations per day
- 200 redundant meter calculations

The bus coupler calculation enables the bus coupler operation of feeders that are fed via auxiliary bus bar during maintenance of the main feeder. This requires meters with a special input card. Converge will add the power consumption of the bus coupler meter to the power consumption of the respective feeder meter.

#### **Interface module**

Several interfaces are connected to the Management Metering Data System for file import and file export. Additionally, the connection of the www100 system also represents an export interface. The interfaces are developed in XML format for standardized exchange of data. The import files could contain load profile meter data of acquired meters from other Management Metering Data Systems or calculated load profile meter data or data from the SCADA system.

Import takes place at a scheduled time each day. If the file does not arrive during this timeframe the best value calculation will be done without considering these load profiles. Handling of import is revised during enhancement. Converge personnel can freely define new import systems and manage them on the operating station.

The export files contain the load profiles of the best value calculation and are sent each day as soon as the calculation modules are finished. These load profiles are further processed by OPCOM, the Romanian Power Market Operator and subsidiary of Transelectrica.

The export for www100 is processed a similar way as for the file export to other systems. The load profiles as power consumption and counter values are automatically transferred into the www100 SQL database.



All interfaces, including the number of meters, need to be set up in the Management Metering Data System before any meter data from the file transfer can be stored in the Converge database. This includes the meter data transferred to the www100 system. Furthermore, user rights such as which user is entitled to access which meter data can be defined. All settings can be defined with the specially developed Export GUI.

**The standard protocols are used for file transfer:**

- Three import interfaces for a total of 3000 meters from other Management Metering Data systems. The number will increase to several 100 import interfaces from small Management Metering Data systems
- Two export interfaces to other Management Metering Data system
- One export interface to www100 system

**Scheduler module**

The scheduler module enables the automatic start of regular jobs. In order to have a flexible system, the data acquisition and data processing modules have their own scheduler. Different schedules can be linked to the job dependency manager, which enables coordination of the jobs that depend on each other. For example, the data check only starts once data acquisition is complete. The scheduler also enables definition of repetition intervals in case communication errors arise during acquisition and reading the meter via a back up modem.

The data acquisition reads the meters two times a day between 3am and 5am and then between 8pm and 10pm. Every time meter data is acquired, Converge calculates the start and end point of the range of data to be retrieved. This feature ensures that no data gaps in the database occur. If, for example, the GSM connection is interrupted during a reading, the system will not shift the end point. Therefore, the next time meter data is acquired, the system reads the data from the last received meter value.

The user definable scheduler starts the data check and best value calculation. This task is started after reading of

all meters is complete, all file imports are received and the calculation of the redundant meter is processed. The redundant meter calculation is automatically performed once a day before the data check. Each meter can also be calculated manually, if necessary.

**Data aggregation module**

This module has been developed according to Romania's regulatory requirements. It enables the various power production/consumption per producer/consumer per license zone at any connecting point within Romania to be calculated, including not measured connecting points. The module allows inserting network parameters such as on/off transformer losses and network impedances.

**Calculation of losses module**

This module has been developed according to regulations set by Romania's National Energy Regulatory Authority (ANRE). For any measuring/accounting point the power losses can be calculated taking the network parameters into account.

**Data view module (subsidiaries)**

The www100 provides meter data to be retrieved by Transelectrica's eight subsidiaries. A workstation at each subsidiary with Internet Explorer and access to an internet service provider are sufficient for retrieving the meter data of www100. For security reasons the www100 server is installed within the demilitarised zone of the network, which prevents access from the internet into the LAN of Transelectrica.

Once the load profiles are retrieved onto the local workstation they can be graphically visualized or displayed in table format. Enhanced calculations can be applied before graphical or tabular visualization takes place.

**Redundancy**

A certain degree of redundancy has been implemented on the software, hardware components and power supply. Vital hardware components such as servers, modems, the comport multiplier and power supplies are installed in redundancy. A component failure will not



impact on the performance of the system. Each server is equipped with two power supply modules, which are either fed from the installed Uninterrupted Power Supply (UPS) or from the independent UPS.

Failure of one power module has no impact on server operation; failure of GSM modems will result in meter data being acquired by backup modems.

The main systems Converge and www100 are installed in redundancy on two different servers. These applications are installed as clusters and therefore the cluster will monitor the proper function of the application. In case of problems, it will switch over to the other system.

#### **Data storage and data back-up**

The load profile values are stored on the modular SAN Array 1000 (MSA1000) of HP on disks in RAID-5 configuration. This is a scalable, high performance 2GB Fibre Channel. During the upgrades that took place in 2006, storage was increased to 1008 GB which gives a storage depth of more than two years. The system is configured so that additional storage capacity can be inserted in plug and play mode. Any disc failure will automatically activate the hot spare disc as replacement. A data backup system for Oracle and SQL DB is provided.

#### **About Transelectrica**

The Romanian power grid company Transelectrica is the Transmission System Operator (TSO) of the entire Romanian power system. It is a joint stock, state-owned company, with a high share of public assets and a high degree of autonomy and functions according to transmission and system operator licenses and the transmission grid code. Transelectrica has eight transmission branches.

#### **Network facilities**

Transmission substation: 77pcs  
OHL total length: 7'900 km  
Overall installed capacity: 36 GVA

#### **Landis+Gyr (Europe= AG**

Theilerstrasse 1  
6301 Zug  
Switzerland

Tel. +41 41 935 6000

Fax +41 41 935 6601

info@landisgyr.com

[www.landisgyr.com/europe](http://www.landisgyr.com/europe)