

Ultrasonic heating and cooling meter
T550 (UH50...)
Residential, district heating, local heating plant

Landis+Gyr+
manage energy better

ULTRAHEAT®T550 (UH50...) ULTRACOLD®T550 (UH50...) Flow sensor T550 (UH50...)



Technical description

32 16 101 001 k
Date : 08.08.2025
Landis+Gyr GmbH

Outstanding features

Meter for measurement of flow and energy in a heat or cold circuit with water using the ultrasonic principle.

Important properties are:

- Non-wearing due to non-moving parts
- Measuring range of 1:100 according to EN1434:2014, 1:1.000 total range
- Power measurement with maximum values, tariffs selectable
- Data logger for system monitoring
- 60 monthly values
- Logbook
- Battery or mains operated
- Optical interface according to EN 62056-21:2003
- Wide range of communication modules (including IoT) for remote readout and system integration
- 2 module slots for using 2 communication modules coincidentally
- Also operable as a flow meter, cooling or combined heat/cold meter
- Self-diagnosis

Contents

1	General notes	5
	Other available documentation	5
2	Safety information	6
3	Technical data	8
	Small meters (qp 0.6 – 2.5 m ³ /h)	10
	Large meters with thread	11
	Large meters with flange	12
	Large meter qp 150	12
4	Installation	13
	Installation Notes	13
	Examples of installation	13
	Installation notes for sensor adapter set (temperature sensor directly immersed)	14
4.1	Installation for cooling metering	15
4.2	Installation of qp 150	15
5	Dimension of electronic unit	16
6	Operating elements	17
6.1	Displaying current meter status	17
	Display values (LOOPS)	18
	User loop "LOOP 0"	18
	Service loop 1 "LOOP 1"	18
	Service loop 2 "LOOP 2"	19
	Service loop 3 "LOOP 3"	19
	Service loop 4 "LOOP 4"	20
6.2	Previous year's values	21
6.3	Monthly values	21
7	Resolution of the display	22
8	Power supply	22
	Automatic power supply detection	22
	Power supply requirements	23
	Power supply modules	23
9	Communication	24
	Electronic unit interfaces	24
	Permissible combinations of modules	25
	Terminals	25
9.1	Pulse module	26
9.2	M-Bus module G4	26
9.3	M-Bus module MI with 2 pulse inputs	27
9.4	Analog module	28
9.5	Radio module 868 MHz (Wireless M-Bus)	28
9.6	Radio module 868 MHz LoRaWAN® (WZU-LR; WZU-LR-EXT)	29
9.7	Radio module NB-IoT (WZU-NB-IoT-G2)	29
9.8	BACnet module (WZU-485E-BAC)	30
9.9	Modbus module (WZU-485E-MOD)	31

10	Tariff control (optional) _____	32
	Threshold value tariff (tariffs T2, T3, T4, T5, T6) _____	32
	Supplied quantity of energy / Adjusted Energy (tariff T7) _____	32
	Returned quantity of energy (tariff T8) _____	32
	Heating/Cooling meter (tariff T9) _____	33
	Tariff control via timer switch (tariff T10) _____	33
	Tariff control via M-Bus (tariff T11) _____	33
	Surcharge quantity tariff by means of return temperature (tariff T12) _____	33
	Display of the tariff situation on the LCD _____	33
11	Error messages _____	35
12	Log functions _____	36
13	Data logger (optional) _____	38
14	Additional options _____	39
15	Order codes (type designation) _____	40
16	Additional ordering information on radio module 868 MHz (wireless M-Bus EN13757-4, OMS v2.0/ OMS v4.1.2) _____	43
17	Additional order information for LoRaWAN® module _____	44
18	Pressure loss _____	45

1 General notes



Note: In the following text, the term meter refers to heating meter, cooling meter and flow meter, unless they are otherwise differentiated.

The meter is used as a meter for heating or cooling consumption measurement in systems with water.

The meter consists of a volume measurement, two temperature sensors and an electronic unit that calculates the energy consumption from the volume and temperature difference.

The meter combines modern microcomputer technology with innovative ultrasonic measurement technology for which no mechanically moving parts are necessary.

This technology is thus wear-free, robust, and largely maintenance-free. High precision and long-term stability guarantee precise and accurate accounts of charges.

Other available documentation

- Operating instructions T550 (UH50...)
- Installation instructions T550 (UH50...)
- Respective module operating and installation instruction
- Illustrated catalogue

Additional information's are available on request.

2 Safety information



The meter may only be used in building service engineering systems and only for the applications described.



The local regulations (installation etc.) must be adhered to.



The operating conditions according to the type plate must be complied with during use. Non-compliance can result in hazardous situations and the expiry of all claims arising from liability for defects as well as liability based on any expressly granted guarantees.



Requirements for circulating water (CEN/TR 16911: 2016).



The meter is only suitable for circulating water in heating systems.



The meter is not suitable for drinking water.



Do not lift the meter by the electronic unit.



Be aware of sharp points on the thread, flange and measuring tube.



Only personnel, trained in the installation and operation of meters in heating and cooling systems, may install and remove the meter.



Only install or remove the meter when the pipes are pressure-less.



After installing the meter, check the leak-tightness of the system.



Guarantee and calibration validity will lapse if the calibration relevant security seal is broken.



Only clean the meter from outside with soft, lightly wet cloth. Do not use any spirit or cleaning solvent.



The 110 V / 230 V connections may only be made by an electrician.



The meter may only be powered up once the installation has been completed. Otherwise, there is a danger of electronic shock on the terminals.

A defective or obviously damaged appliance must be disconnected from the power supply immediately and replaced.



As far as disposal is concerned, the meter is a waste electronic appliance in the sense of European Directive 2012/19/EU (WEEE), and it must not be disposed of as domestic waste. The relevant national legal regulations must be observed as the appliance must be disposed of via the channels provided for this purpose. The local and currently valid legislation must be observed.



The meter contains lithium batteries. Do not dispose of the meter and the batteries with domestic waste. Observe the local stipulations and laws on disposal.



You can return the lithium batteries to the manufacturer for appropriate disposal following use. When shipping please observe legal regulations those governing the labelling and packaging of hazardous goods.



Do not open the batteries. Do not bring batteries into contact with water or expose to temperatures above 80 °C.



The meter does not have any lightning protection. Ensure lightning protection via the in-house installation.



Only fit one compartment for the voltage supply. Do not remove the red locking hatch.

3 Technical data

General

Measuring accuracy	Class 2 or 3 (EN 1434)
Environment class	A (EN 1434) for indoor installation
Mechanical class	M1 *)
Electromagnetic class	E1 *)
*) according to 2014/32/EU Directive on Measuring Instruments	
Ambient humidity	< 93 % rel. humidity at 25°C, without condensation
Max. height	2000 m above sea level
Storage temperature	-20 ... 60 °C

Electronic unit

Ambient temperature	5 ... 55°C
Housing protection rating	IP 54 according to EN 60529
Safety class	
Line 110 / 230 V AC	II according to EN 61558
Line 24 V ACDC	III according to EN 61558
Operation threshold f. ΔT	0.2 K
Temperature difference ΔT	3 K ... 120 K
Temperature measurement range	0 ... 180°C
LCD	7 digits
Optical interface	Standard, EN 62056-21
Communication	Optional, e.g. M-Bus
Separability	Always, optional cable length

Temperature sensor

Type	Pt 500 or Pt 100 According to EN 60751
Temperature range	0 ... 150°C (up to 45 mm overall length) 0 ... 180°C (from 100 mm overall length)

Volume measurement unit

Protection class	IP 54 / IP 65 / IP 68 according to EN 60529
Mounting place	Hot side / cold side
Installation position	Any
Flow straightening	None
Measuring range	1:100
Temperature range	5 ... 130°C 25 ... 130 °C for flow sensor National type approvals may be different.
Recommended...	
...heating application	10 ... 130°C
...cooling application	5 ... 50°C
Maximum overload	2,8 × qp
Nominal pressure	PN16 (PS16), PN25 (PS25)

Nominal flowrate q_p	Overall length	Connection	Maximum flowrate q_s	Minimum flowrate q_i	Response threshold (variable)	Pressure loss at q_p	Kv flowrate at Δp 1 bar	Kv flowrate at Δp 100 mbar	Weight
m ³ /h	mm	G/DN	m ³ /h	l/h	l/h	mbar	m ³ /h	m ³ /h	kg
0.6	110	G 3/4	1.2	6	2.4	150	1.5	0.5	1
0.6	130	G1	1.2	6	2.4	150	1.5	0.5	1.5
0.6	190	G1	1.2	6	2.4	150	1.5	0.5	1.5
0.6	190	DN20	1.2	6	2.4	150	1.5	0.5	3
1.5	110	G 3/4	3	15	6	170	3.9	1.2	1
1.5	130	G1	3	15	6	160	3.8	1.2	1.5
1.5	190	G1	3	15	6	160	3.8	1.2	1.5
1.5	190	DN20	3	15	6	160	3.8	1.2	3
2.5	130	G1	5	25	10	200	5.6	1.8	1.5
2.5	190	G1	5	25	10	210	5.3	1.7	1.5
2.5	190	DN20	5	25	10	210	5.3	1.7	3
3.5	260	G 1 1/4	7	35	14	55	15	4.7	3
3.5	260	DN25	7	35	14	55	15	4.7	5
6	150	G 1 1/4	12	60	24	190	14	4.4	3
6	260	G 1 1/4	12	60	24	140	16	5.1	3
6	260	DN25	12	60	24	140	16	5.1	5
10	200	G2	20	100	40	130	28	8.8	2.6
10	300	G2	20	100	40	110	30	9.5	4
10	300	DN40	20	100	40	130	28	8.8	7
15	200	DN50	30	150	60	95	49	15.4	5
15	270	DN50	30	150	60	110	45	14.3	8
25	300	DN65	50	250	100	105	77	24.4	11
40	300	DN80	80	400	160	160	100	31.6	13
60	360	DN100	120	600	240	115	177	56.0	22
150	500	DN150	300	1500	600	120	433	136.9	50*)

*) Measurement insert 4 kg

Tolerance of pressure lost: +/- 5%

Small meters (qp 0.6 – 2.5 m³/h)

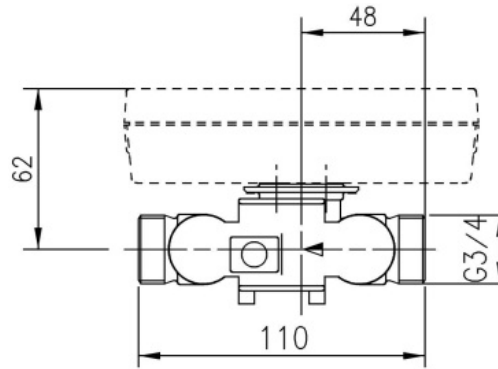

Fig. 1: Overview dimensions overall length 110 mm

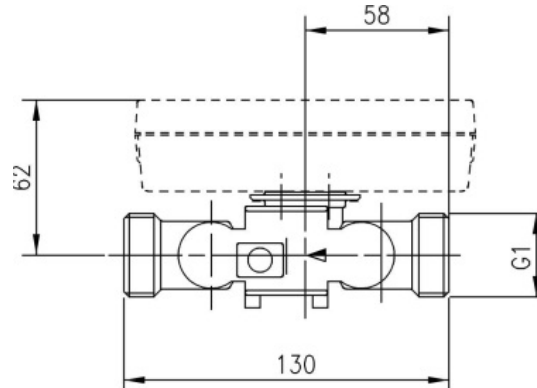

Fig. 2: Overview dimensions overall length 130 mm (thread)

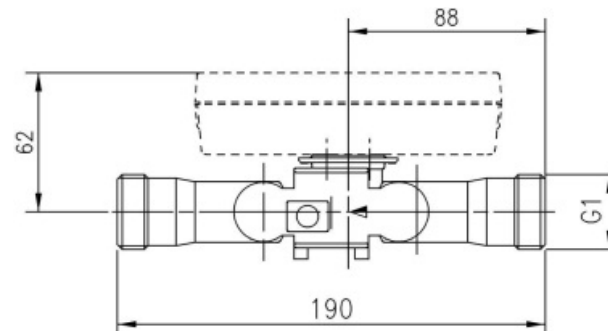

Fig. 3: Overview dimensions overall length 190 mm (thread)

Order-No.	qp m³/h	PN bar	a mm	b mm	c mm
UH50-x03	0.6	16	130	G1	58
UH50-x04	0.6	25	130	G1	58
UH50-x05	0.6	16	110	G ¾	48
UH50-x06	0.6	25	110	G ¾	48
UH50-x07	0.6	16	190	G1	88
UH50-x09	0.6	25	190	G1	88
UH50-x21	1.5	16	110	G ¾	48
UH50-x22	1.5	25	110	G ¾	48
UH50-x23	1.5	16	190	G 1	88
UH50-x25	1.5	25	190	G1	88
UH50-x26	1.5	16	130	G1	58
UH50-x27	1.5	25	130	G1	58
UH50-x36	2.5	16	130	G1	58
UH50-x37	2.5	25	130	G1	58
UH50-x38	2.5	16	190	G1	95
UH50-x40	2.5	25	190	G1	95

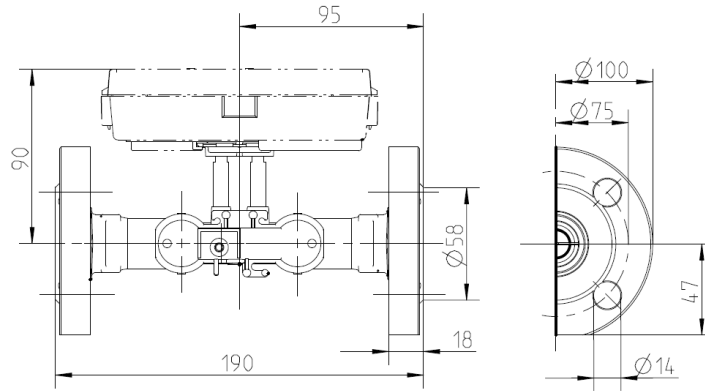

Fig: Overview dimensions overall length 190 mm (flange)

Order-No.	qp	PN	Overall length	Connection
	m ³ /h	bar	mm	
UH50-x08	0.6	25	190	DN20
UH50-x24	1.5	25	190	DN20
UH50-x39	2.5	25	190	DN20

Large meters with thread

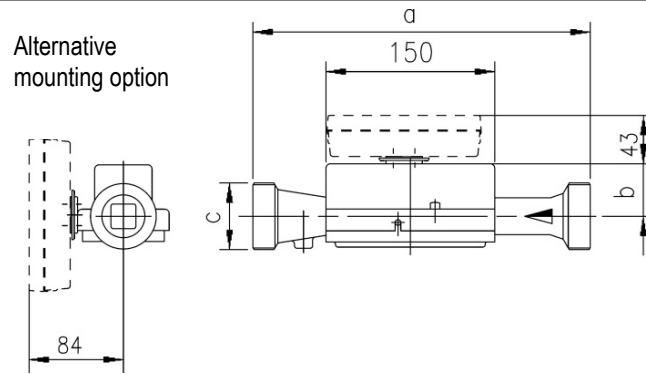

Fig. 5: Overview dimensions of large meters with thread

Order-No.	qp	PN	a	b	c
	m ³ /h	bar	mm	mm	
UH50-x45	3.5	16	260	59	G 1¼ B
UH50-x47	3.5	25	260	59	G 1¼ B
UH50-x50	6	16	260	59	G 1¼ B
UH50-x51	6	25	260	59	G 1¼ B
UH50-x60	10	16	300	59	G 2 B
UH50-x62	10	25	300	59	G 2 B
UH50-x63	10	16	200	59	G 2 B

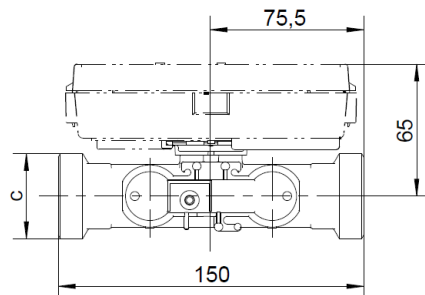

Fig. 6: Overview dimensions of large meters qp 6 with tread (short face-to-face length)

Order-No.	qp	PN	c
	m ³ /h	bar	
UH50-x55	6	16	G 1¼ B

Large meters with flange

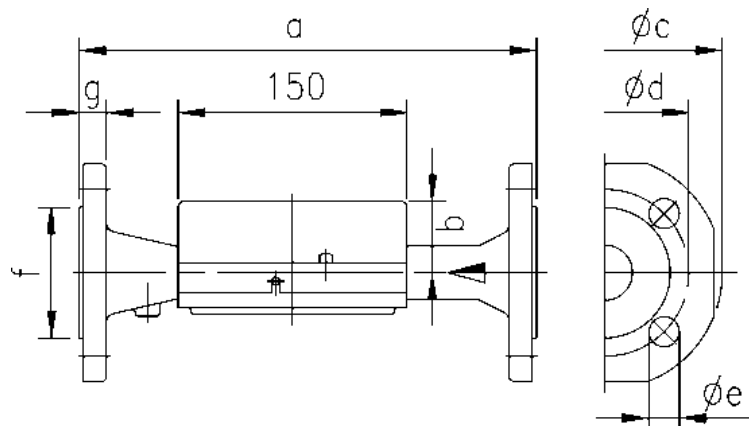

Fig. 7: Overview dimensions of large meters with flange

Order-No.	qp m³/h	PN bar	DN	a mm	b mm	Øc mm	Ød mm	Øe mm	No. of holes	f mm	g mm
UH50-x46	3.5	25	25	260	59	112	85	14	4	60	19
UH50-x52	6	25	25	260	59	112	85	14	4	60	19
UH50-x61	10	25	40	300	59	140	110	18	4	90	19
UH50-x65	15	25	50	270	59	155	125	18	4	102	20
UH50-x69	15	25	50	200	59	155	125	18	4	102	20
UH50-x70	25	25	65	300	52	185	145	18	8	122	22
UH50-x74	40	25	80	300	56	200	160	18	8	138	24
UH50-x82	60	16	100	360	68	235	180	18	8	158	24
UH50-x83	60	25	100	360	68	235	190	22	8	158	24

Large meter qp 150

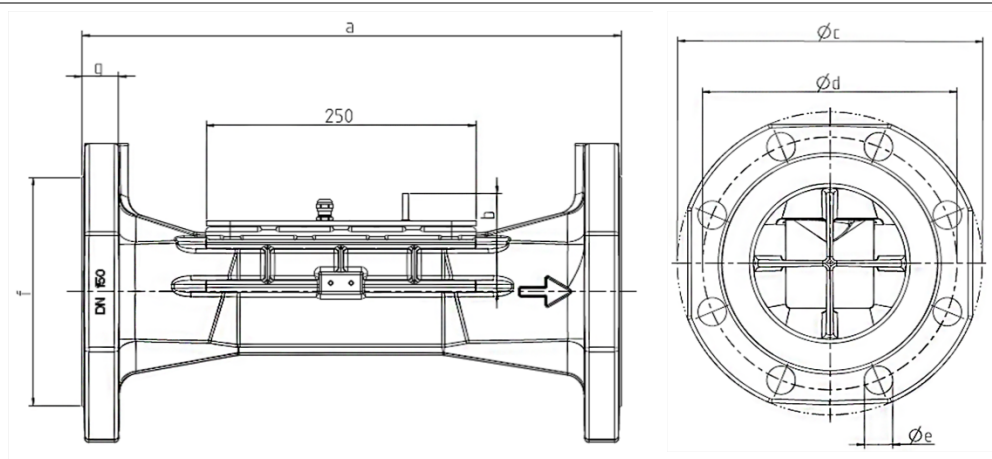

Fig. 8: Overview all dimensions of large meter qp 150

Order-No.	qp m³/h	PN bar	DN	a mm	b mm	Øc mm	Ød mm	Øe mm	No. of holes	f mm	g mm
UH50-xA1	150	16	150	500	91	300	240	23	8	211	31
UH50-xA2	150	25	150	500	91	300	250	28	8	211	31

4 Installation

To install the meter, proceed as follows:

- Determine the place of installation in line with the inscription on the meter.



Note: At a **heat meter** or combined heating/cooling meter the mounting place of the flow sensor cold side is equivalent to return flow. The mounting place of the flow sensor hot side is equivalent to flow.



Note: At a **cooling meter** the mounting place of the flow sensor hot side is equivalent to the return flow. The mounting place of the flow sensor cold side is equivalent to flow.

- Observe the dimensions of the meter and check whether there is sufficient space available.
- Rinse the system thoroughly before installing the meter.
- Fit the meter vertically or horizontally between two slide valves so that the arrow on the housing and the flow direction match. Also observe the installation situations and the following examples of installation.
- Fit the temperature sensors in the same circuit as the meter.



Note: For meters up to qp 6 and up to PN16 the temperature sensors should be installed directly immersed. Only use pockets for higher loads.

- Seal the temperature sensors and the fittings to protect against manipulation.
- Loosen the elastic band or the cable tie, provided for the transport, from the volume measurement unit. In operation, the temperature sensor and the control cable should not depend directly on the volume measurement unit.
- If you install the meter for cooling metering, follow the appropriate notes.

Installation Notes

Inlet or outlet sections are not necessary. If you install the meter in the common return of two circuits, determine a place of installation with a minimum distance of $10 \times DN$ from the T-piece. This distance ensures a good thorough mixing of the different water temperatures. You can install the temperature sensors in T-pieces, ball valves, directly immersed or in pockets depending on the version. The temperature sensor ends must reach to at least the middle of the pipe cross section.



Note: During installation it must be ensured that no water can enter the electronic unit during operation.

Examples of installation

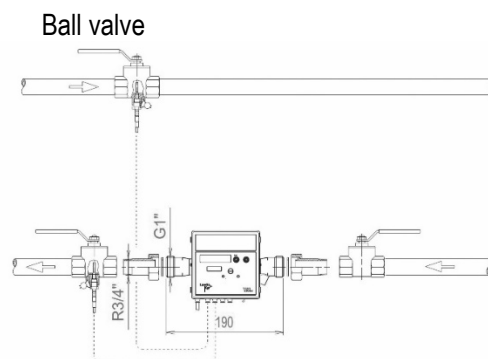

Fig. 9: Installation with a ball valve (recommended up to and including qp 6)

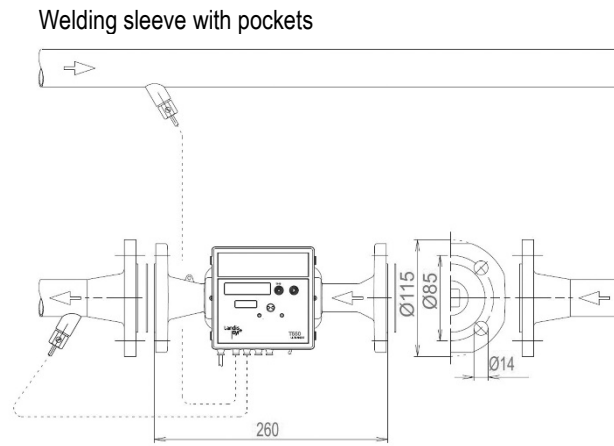

Fig. 10: Installation with pockets (recommended greater than or equal to qp 10)

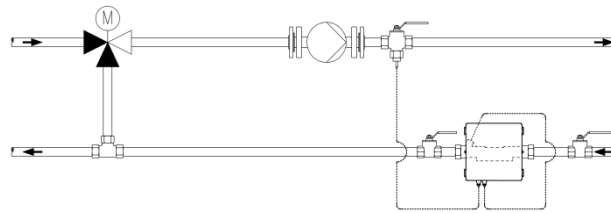

Fig. 11: Installation for circulation with admixing; placement of temperature sensors

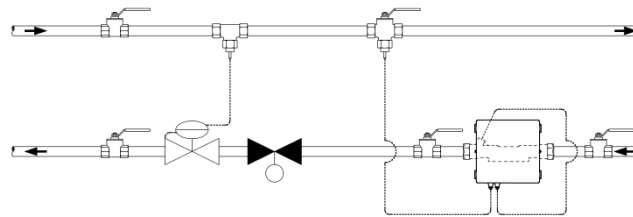

Fig. 12: Installation for circulation with throttling configuration for example (flow sensor in flow direction upstream control valve / differential pressure regulating valve)

Installation notes for sensor adapter set (temperature sensor directly immersed)

A mounting set is included for meters with 5.2 × 45 mm temperature sensors. It allows for mounting the temperature sensors directly immersed into an insert or a ball valve for example.

1. Install with the O-ring at the point of installation with the fit-up aid/pen provided.
2. Place both halves of the plastic bolting round the 3 notches of the temperature sensor.
3. Press the bolting together and screw the bolting hand tight into the point of installation until it comes to a stop (tightening torque 3 ... 5 Nm).

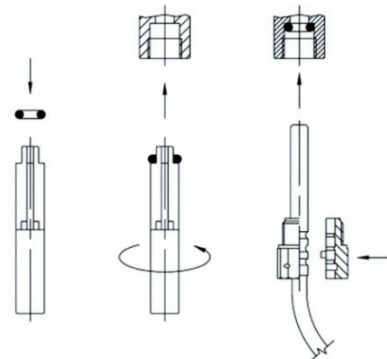

Fig. 13: Mounting adapter set

4.1 Installation for cooling metering

When installing as a cold meter or combined heating/cooling meter, ensure that the black cover on the measuring tube is facing to the side or downwards to prevent problems with condensation forming. Fit the immersion sleeves so that the temperature sensor is positioned vertically downwards or horizontally. Fit the electronic unit separate to the volume measurement tube, e.g., on the wall. Form a loop downwards to prevent condensation running along the connected lines into the electronic unit.

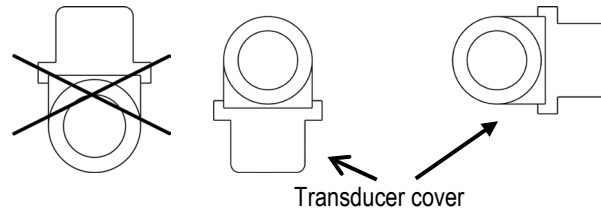

Fig. 14: Recommended installation position for cooling metering

4.2 Installation of qp 150



Note: Use flange bolts with a length of at least 100 mm to install the flanged body in the pipeline.

As an assembly aid 2 M10 threads are mounted on the flange. The threads allow for the use of stainless-steel eye bolts, for example, for a lifting device.



Note: The measurement insert in the flanged body should be positioned on the top. This allows a simple exchange of the measurement insert.

5 Dimension of electronic unit

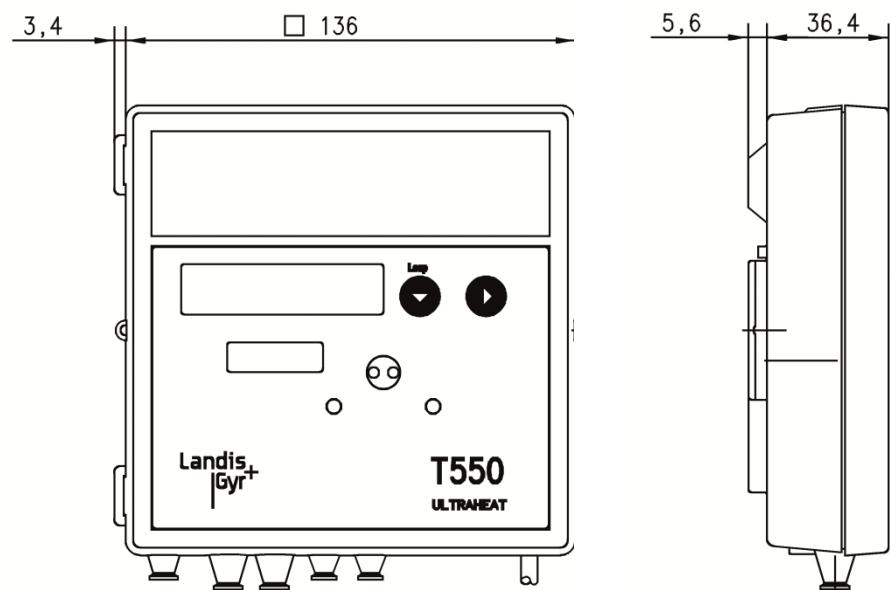

Fig. 15: Dimensions of electronic unit

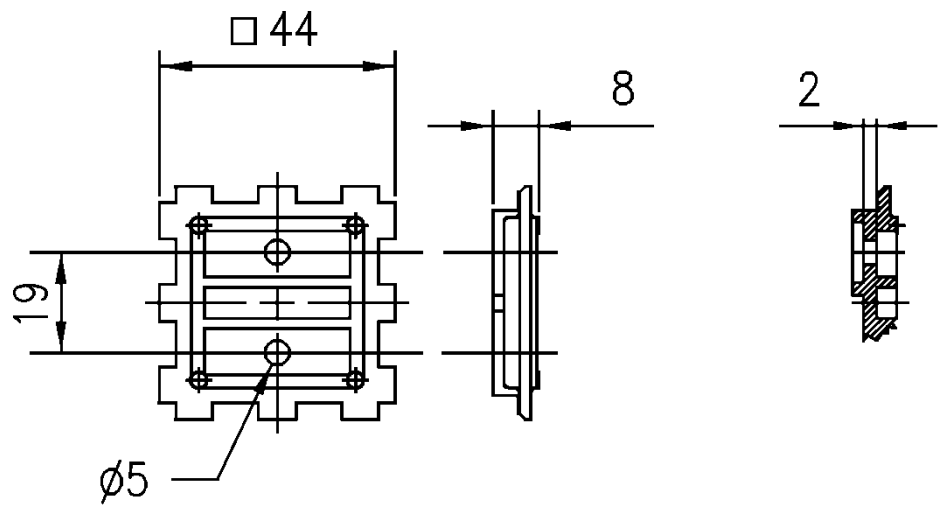

Fig. 16: Plan view and cross section of adapter plate

6 Operating elements

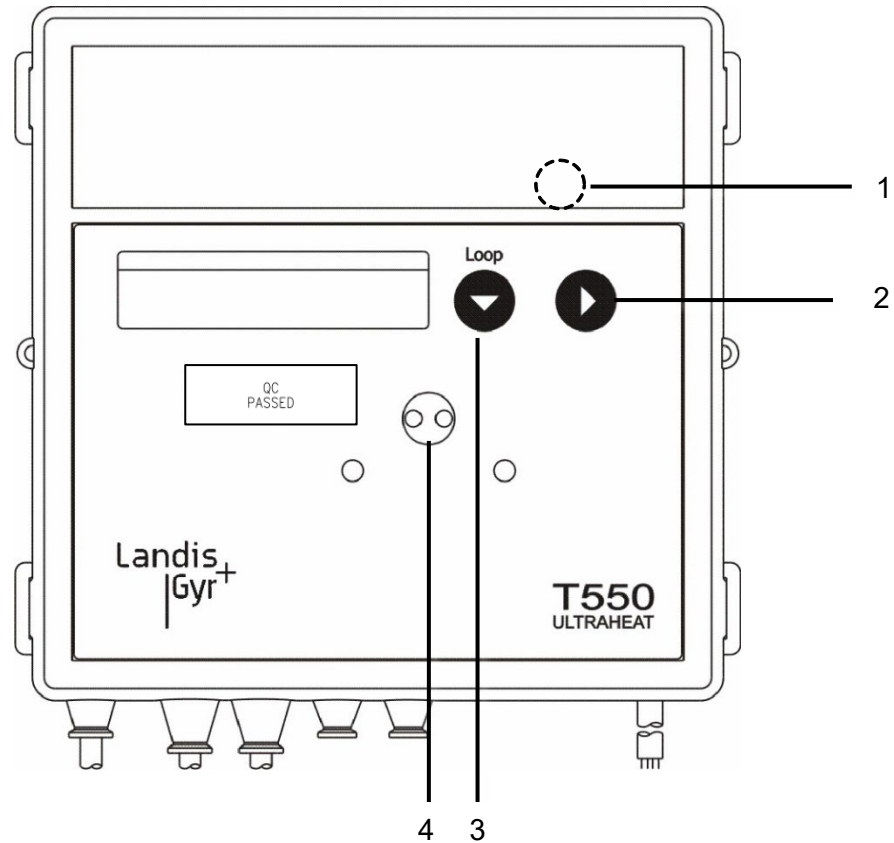

Fig. 17: Operating elements

No.	Name	Description	Note
1	Service button	To call up the parameterization operation of the meter.	Accessible after removing the cover.
2	Button 2	Switches to the next display value within a loop.	
3	Button 1	Switches to the next loop.	
4	Optical interface	Permits data communication via a computer with the necessary service software.	

6.1 Displaying current meter status

The meter displays the current meter status in kWh, MWh, MJ or GJ.



Note: To avoid reading errors, the decimal places of the displayed values are highlighted with a frame.



Note: Calibrated values are indicated by an additionally displayed star symbol.



Note: Both display range and data displayed can differ from the description depending on the appliance parameterization. Certain button functions can also be blocked.

Display values (LOOPS)

LOOP 0	User loop
LOOP 1	Service loop 1
LOOP 2	Service loop 2
...	...
LOOP 0	User loop

After the last loop is displayed, the user loop “LOOP 0” comes up again.

User loop “LOOP 0”

The LCD shows the following values one after the other:

-- 1234567 kWh	Energy accumulated with tariff status
T' 1234567 kWh	Tariff register 1 (optional)
1234567 m ³	Volume accumulated
8,8,8,8,8,8 kWh	Segment test
LOOP 0	Head of the loop
F - - - - -	In case of error: message with error code

Service loop 1 “LOOP 1”

Service loop 1 displays the details of the current measurement.

The LCD shows the following values one after the other:

LOOP 1	Head of the loop
1234 m ³ /h	Current flow
904 kW	Current power
TV 916 °C	TV current temperature hot side, TR current temperature cold side;
TR 562 °C	in 2-sec. cycles
Id 1234 h	Operating time
Pd 1234 h	Operating time with flow
Fd 123 h	Missing time
K 12345678	Property number, 8-digit

II 10,05,06	Date
SD 3 105,--	Yearly set day (DD.MM)
1234567 kWh	Energy: previous year on set day
1234567 m ³	Volume: previous year on set day
FW 1 5-00	Firmware version

Service loop 2 "LOOP 2"

Service loop 2 displays the measurement period for establishing the maximum.

The LCD displays the following values one after the other:

LOOP 2	Head of the loop
MP 60 min	Measurement period for establishing the maximum

Service loop 3 "LOOP 3"

Service loop 3 displays the monthly values.

LOOP 3	Head of the loop
...	...
0 107,11 M	Set day for July 2011

The LCD displays the following values one after the other:

123456,7 kWh	Energy on the set day
T 1234567 kWh	Tariff register 1 on the set day
1234567 m ³	Volume on the set day
Ma 3899 m ³ /h	Max. flow on the set day, in 2-sec. cycles with date stamp
St 1306,11	
Ma 288,9 kW	Max. power on the set day, in 2-sec. cycles with date stamp
St 1306,11	
MV 98,8 °C	
St 1306,11	Max. temperatures on the set day, in 2-sec. cycles with date stamp
MR 87,7 °C	MV for hot side or MR for cold side
St 1306,11	

Fd 123 h	Missing time count on the set day
----------	-----------------------------------

After the last display, the previously selected set day is displayed once again.

i **Note:** If the number of months to be read out is changed with the service software, this will have an impact on the number of retrievable months in the LCD.

Service loop 4 "LOOP 4"

Service loop 4 displays appliance parameters.

The LCD displays the following values one after the other:

LOOP 4	Head of the loop
T2 0,000 m³/h	Current tariff, in 2-sec. cycles with threshold value 1
' 0,000 m³/h	
FP 2,00 SEC	Measurement interval flow
TP 30 SEC	Measurement interval temperature
Modul 1 MB	Module 1: M-Bus module
AP1 127	M-Bus primary address 1
A 12345678	M-Bus secondary address 8-digit
Modul 2-1 EE	Module 2: Pulse module; channel 1 = energy, channel 2 = volume; in 2-sec. cycles
Modul 2-2 EV	
PO1 125,00Wh/l	Value for energy pulses *)
PO2 0,0250 l/l	Value for volume pulses *)
PO3 2ms	Pulse duration in in ms *)

*) for "fast pulse"

6.2 Previous year's values

The meter saves the following values on the yearly set day

- Energy (meter status)
 - Volume (meter status)
 - Tariff register (meter status)
 - Missing time (meter status)
 - Flow measurement time (meter status)
- and the maxima with date stamp for
- Flow
 - Power
 - Temperature difference
 - Temperature hot side
 - Temperature cold side

6.3 Monthly values

The meter stores the following values for 60 months on the monthly set day

- Energy (meter status)
 - Volume (meter status)
 - Tariff register (meter status)
 - Missing time (meter status)
 - Flow measurement time (meter status)
- and the maxima with date stamp for
- Flow
 - Power
 - Temperature difference
 - Temperature hot side
 - Temperature cold side

The monthly values can be read via the optical and the 20 mA-interface.



Note: Central European Time (CET) applies as the standard time. During summertime, the storage takes place at the corresponding times.

7 Resolution of the display

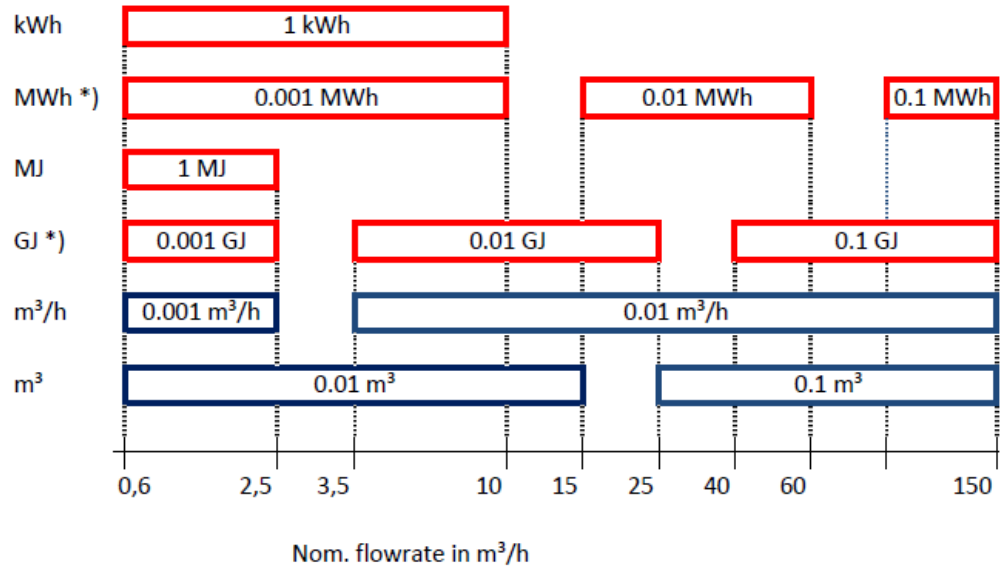

*) Places after decimal point "blinking", "static" or "suppressed"



Note: The number of places after the decimal point of a value is based on the chosen measurement path and the chosen dimension.

8 Power supply

The meter can be supplied with power via a battery or via power supply modules as preferred. Battery and power supply are replaceable at any time.

Options:

- 6 years battery
- 11 years battery
- 16 years battery
- Power supply 110 / 230 V AC
- Power supply 24 V ACDC

Automatic power supply detection

The power supply detects whether a line voltage is applied. This signal is routed to the meter. That enables the device to detect automatically whether it is being powered from a battery or power supply.

Power supply requirements

Requirements (for measuring time base Q = 4 s and time base T = 30 s)	6 years	11 years	16 years	Power supply (110 / 240 V AC; 24 V ACDC)
Standard pulses, M-Bus read out (max. each 15 min.), BACnet / Modbus module	2x AA	C	D	yes
Radio module 868 MHz (mobile radio; 16 sec. transmission interval)	D	D	--	yes
Radio module 868 MHz (stationary radio; 15 min. transmission interval)	D	D	D	yes
M-Bus fast read out (max. each 4 sec.), fast pulses, analog module	D	--	--	yes
Fast measurement raster (for measuring time base Q = 4 s and time base T = 4 s)	D	--	--	yes
Radio module LoRaWAN® 868 MHz <small>*) in EcoMode **) Restrictions see module instructions</small>	D	D*)	D*)	yes**))
Radio module NB-IoT G2 Band 3, 8, 20 <small>***) and additional battery for NB-IoT (WZU-NB-IoT-BAT)</small>	C***)	--	--	yes
BACnet / Modbus module <small>Reading interval < 10 min.</small>	D	--	--	yes



Note: The lifetime of battery depends on the type of battery and on the requirements.



Note: Only batteries approved by the manufacturer may be installed.

Power supply modules

General

Pollution degree	per EN 61010 (no or only dry, non-conductive soiling)
Ambient temperature	+ 5...+55°C
Storage temperature	-25...+70 °C
Relative humidity	5...90 % non-condensing T < 55°C

24°V° safety extra-low voltage

Voltage	12...35 V AC or 12...50 V DC
Frequency	50 / 60 Hz or DC
Galvanic isolation	yes
Power consumption	maximum 2.5 W

Terminals for connecting cable	2 x 1.0 mm ² about, Ø 5.0...6.0 mm
Bridging time in case of power failure (power reserve)	approx. 30 minutes

100 - 240 V alternating voltage *)

Voltage	100...240 V AC (±10%)
Type	Safety class II
Frequency	50 / 60 Hz
Line voltage fluctuations	maximal 10% of the nom. voltage
Overvoltage II per EN60010	2500 V pulse voltage
Power consumption	maximal 2.5 W
Fuse protection	6 A MCB
Bridging time in case of power failure (power reserve)	approx. 4 hours

*) Has two outputs. One supplies the meter, the other an optionally plugged NB-IoT module.



Note: Only use cables with a diameter of 5.0 ... 6.0 mm for the 24 V ACDC version.



Note: The 110 V or 230 V power supply must be marked near the meter with a 6 A overcurrent protection device with disconnect function in accordance with the applicable safety standards

- marked,
- be secured against tampering and
- be easily accessible in case of emergency.

If the neutral conductor in the building installation cannot be clearly identified and safely grounded (e.g. in IT supply systems), an all-pole disconnecting device must be used.

9 Communication

Electronic unit interfaces

The meter is equipped with an optical interface in accordance with EN 62056-21:2002 as standard.

You can additionally use the remote reading with up to 2 of the following communication modules:

- Pulse module
- M-Bus module G4
- M-Bus module G4 MI with 2 pulse inputs
- Analog module
- Radio module 868 MHz
- GPRS module
- BACnet module
- Modbus module
- LoRaWAN[®] module
- NB-IoT-module

These modules do not have any effect on the measurement. You can retrofit the modules at any time without damaging the security seal.



Note: You will find the technical details and data on communication modules in their respective documentation.

Permissible combinations of modules

Step 1							Step 2
Slot for module #2 is equipped with...							
Analog module (3)	Pulse module		MB G4	RF 868 MHz	LoRaWAN®	NB-IoT	Slot for module #1 can be equipped with...
	"standard"	"fast"*					
yes	yes	yes	yes	yes	yes	no	Analog module
yes	yes (2)	yes (1)	yes	yes	yes	yes	Pulse module** "standard"
yes	yes	yes	yes	yes	yes	yes	MB G4
yes	yes	yes	yes	yes	yes	no	MB MI
no	no	no	yes	no	no	no	Modbus
no	no	no	yes	no	no	no	BACnet

Restrictions:

- *) only 1 module with fast pulses is possible; only permissible on slot 2; min. pulse duration:
 - 2 ms, if pulse module 1 not fitted
 - 5 ms, if pulse module 1 fitted
- **) Subsequent mounting of a further pulse module in module slot 1 can result in changed output values for module 2!
 - (1) Pulse length of the fast pulses min. 5 ms
 - (2) The first and second channel can be parameterized individually!
 - (3) The analog module is not possible in module slot 2, when the meter has a power supply module 110 V / 230 V!

Terminals

2-pole or 4-pole terminals are used for connection of the external cables to the modules.

- Outer diameter of the cable 4 ... 6 mm
- Connection capacity
 - rigid or flexible 0.2 ... 2.5 mm²
 - flexible with wire end ferrule 0.25 ... 1.5 mm²
 - conductor sizes 26 ... 14 AWG

- Multiple conductor connector (2 conductors with the same cross-section)
 - rigid or flexible, 0.2 ... 0.75 mm²
 - flexible with wire end ferrule without plastic sleeve, 0.25 ... 0.34 mm²
 - flexible with TWIN wire end ferrule with plastic sleeve, 0.5 ... 0.75 mm²
- Strip-back length 5 mm
- Recommended screwdriver:
 - 0.6 × 3.5 mm
- Tightening torque: 0.4 Nm

9.1 Pulse module

The pulse module permits the output of pulses that can be derived from the quantity of heat, the volume, tariff register 1, tariff register 2 or the mistake status. Two channels are available whose functions can be parameterized with the service software.

Output takes the form of standard pulses or “fast pulses”. The pulse duration is identical for channel 1 and channel 2.

Labeling	pulse module
Display in LCD	CE, C2, CV, CT or RI
Type	open collector
Voltage	max. 30 V
Current	max. 30 mA
Dielectric strength	500 V _{eff} against ground
Classification	OB (per EN 1434-2)
Voltage drop	approx. 1.3 V at 20 mA
Classification	OC (per EN 1434-2)
Voltage drop	approx. 0.3 V at 0.1 mA
Output connection (WZU-P2):	

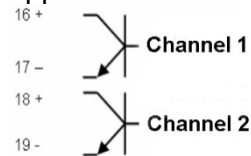

9.2 M-Bus module G4

The M-Bus module enables the meter to communicate with an M-Bus center in order to transmit measured values.

Standard	EN 1434-3; EN 13757-2, -3
Protocol	EN 60870-5
Electrical isolation	
from the meter	yes
from the pulse inputs	no
Connection	
Strip-back length	5 mm
Connection capacity	
rigid or flexible	0.25 ... 0.75 mm ²
flexible with wire end ferrule	0.25 ... 0.75 mm ²
Polarity	any
Voltage	50 V DC maximal
Current consumption	1 M-Bus load (1.5 mA)
Addressing	primary or secondary
Baud rate	300, 1200, 2400, 4800 or 9600 baud
Interface description	see TKB3448

9.3 M-Bus module MI with 2 pulse inputs

The M-Bus module enables the meter to communicate with an M-Bus center in order to transmit measured values. In addition to a possible voltage supply from the M-bus connection, the “MI” module is equipped with a battery. This powers the module processor and the pulse input if no M-bus voltage is applied.

M-Bus	
Standard	EN 1434-3; EN 13757-2, -3
Protocol	EN 60870-5
Electrical isolation	
from the meter	yes
from the pulse inputs	no
Connection	
strip-back length	5 mm
Connection capacity	
rigid or flexible	0.25 ... 0.75 mm ²
flexible with wire end ferrule	0.25 ... 0.75 mm ²
Polarity	any
Voltage	50 V DC max.
Current consumption	1 M-Bus load (1.5 mA)
Addressing	primary or secondary
Baud rate	300, 1200, 2400, 4800 or 9600 baud
Interface description	see TKB3448
Pulse	
Number of pulse inputs	2 pulse inputs per “MI” module
Life of the module battery	5 years of operation + 1-year storage duration; if the M-bus voltage is applied for at least 90% of the operating time, the battery life increased to 10 years
Standard for pulse inputs	Class IB per EN 1434-2
Frequency	Max. 10 Hz
Pulse duration (low)	≥ 50 ms
No-pulse duration (high)	≥ 50 ms
Pulse value	0.01 liters/pulse, in steps of 10 000.00 liters/pulse, in steps of 0.01 liters/pulse
Display and output	in m ³ , 7-digit; acc. to parameter setting with or without 1 decimal place
Polarity	yes, must be correct if transmitter is of type “open collector”
Electrical isolation	from the meter: yes from the M-bus inputs: no
Output voltage	approx. 3.3 V
Internal resistance	approx. 1 MΩ
Source current	approx. 3 μA
Pulse input closed (low)	Switching threshold low < 0.2 V Resistance < 50 kΩ
Pulse input open (high)	Switching threshold high: unconnected collector Resistance ≥ 6 MΩ
Connection	Strip-back length 5 mm
Connection capacity	

rigid or flexible	0.25 ... 0.75 mm ²
flexible with wire end ferrule	0.25 ... 0.75 mm ²
Permissible cable length	Max. 10 m

9.4 Analog module

The analog module converts the measured value from the meter to an analog signal.

Power supply range	12 ... 30 V AC
Power supply protection	
< 24V	200 mA, slow blow
≥ 24V	100 mA, slow blow
Max. current consumption	170 mA @ 12 Volt
Power consumption	Max. 2 Watt
Max. output load	300 Ohm for current output, 2kOhm for voltage output (outputs are short circuit proof)
Accuracy	≤ ± 1% of parameterized max. value
Max. length of connections	100 m
Outer diameter of connections	up to 1.5 mm ²

9.5 Radio module 868 MHz (Wireless M-Bus)



Note: For meter of the type T550 firmware ≥ 5.17.
 For meter of the type T550 firmware ≥ 5.23 new functions are availed (C1 mode, OMS 4.1.2 with security profile B).

The radio module 868 MHz enables the meter to communicate with a center (receiver) using 868 MHz radio frequency. The module supports OMS – compliant data transmission with radio mode T1 or C1 and with or without encryption (see chapter 16, 17). A data transmission to an OMS radio concentrator (Smart Meter Gateway) or the Landis+Gyr mobile radio readout system Q4 is possible.

Transmission frequency at T1	868.95 MHz (868.90 MHz up to 869.00 MHz)
Transmission frequency at C1	868.95 MHz (min. 868.928 MHz to max. 868.972 MHz)
Transmission power (ERP)	min. 3.16 mW (5 dBm) up to max. 25 mW (13.9 dBm)
Antenna	internal or external (from our accessories, with SMA connector)
Range *)	
Free field	up to 400 m
Inside buildings	e.g. horizontally 30 m
Power supply via meter **)	Battery type D mobile radio (16 seconds) battery for 11 years; stationary radio (15 minutes) battery for 16 years
via power supply	110/230/24 V
Standard	EN13757-2/ -4

*) Depending on the structure of the building can deviate significantly.
 **) If the battery of the meter is of any other type, it must be replaced by a battery of type D. This battery lifetime is valid for the standard data telegrams (P600, P601) and T550 with standard measuring interval for flow and temperature.

9.6 Radio module 868 MHz LoRaWAN® (WZU-LR; WZU-LR-EXT)

 **Note:** For T550 with firmware ≥ 5.15.

 **Note:** The module is displayed as “MB G4” on the LCD.

The LoRaWAN® module sends meter data via LoRaWAN® network to an application Server. The end customer also has access to the application server. The meter data is sent immediately after the start. The module can be parameterized using the mobile “Elvaco OTC APP” from Elvaco. Registration and access to the module keys is via the OTC web service provided by Elvaco.

Frequency	868 MHz
Transmission power (ERP)	25 mW (14 dBm)
Antenna	Internal or external (from our accessories, with SMA connector)
Range*)	
free field	10 km
inside buildings	100 m
Power supply	
via calculator **)	Battery type D Transmission interval 60 minutes battery for 11 years Transmission interval 160 minutes battery for 16 years
via power supply	110/230/24 V (not with Elvaco 24V)
Standard	LoRaWAN Version 1.0 (Class A bi-directional)

*) Depending on the structure of the building can deviate significantly.
 **) If a different battery is installed, it must be replaced with type D.

9.7 Radio module NB-IoT (WZU-NB-IoT-G2)

 **Note:** For T550 with firmware ≥ 5.15.

 **Note:** The module is displayed as “MB G4” on the LCD.

The NB-IoT module sends meter data via a NB-IoT mobile network to an application server (central office), which the end customer also has access to. The meter data is sent immediately after startup. The module can be parameterized with the mobile "Elvaco OTC APP" from Elvaco. Registration and access to the keys of the modules is done via the OTC Web Service of Elvaco.

Band (Frequency)	3 (1800 MHz), 8 (900MHz), 20 (800MHz)
SIM card format	“4FF” (Nano-SIM)
Transmission Power (ERP)	max. 200 mW (23 dBm)
Antenna	for external antennas with MCX connector from our accessories
Range*)	
free field	10 km
inside buildings	100 m

Transmission interval	Max. every 5 minutes
Power supply	
Mains supply via power supply unit	WZU-ACDC24-50 (with 2 outputs); WZU-AC110/230-xx (with 2 outputs)
Battery for NB-IoT with holder **)	WZU-NB-IoT-BAT
	Transmission interval daily (hourly profile of the last day) 7 years lifetime (with ECL0)
Standard	3GPP release 14 (NB2)
*) Depending on the structure of the building can deviate significantly.	
**) The meter requires an additional battery type C cell (WZU-BC+GUM) in the left compartment.	

9.8 BACnet module (WZU-485E-BAC)

WZU-485E-BAC is an add-on communication module for the following types of meters: T550 (UH50...) (firmware 5.15 and higher) and T550 (UC50...). The module is intended and preconfigured for data transmission using the BACnet MS/TP (RS485) protocol.

General information	
Communication protocol	BACnet MS/TP (RS485) acc. to ASHRAE 135 and ISO 16484-5
Supported BACnet Services	BACnet Application Specific Controller (B-ASC) BACnet Master Mode
BACnet address range	1 – 127
Transmission rate	9600 / 19200 / 38400 / 76800 bps
Communication address	M-Bus primary address of T550 (Loop 4: 1127)
Data refreshing	Stand-by mode: 60 min In operation: After every data request, up to 10s
Default settings	
Transmission rate	38400 bps
Communication address (T550)	0 (meter default – must be changed)
RS485 information	
HW network connection	RS485: A+, B-, GND communication signal inputs (A, B) are protected against short-term (pulse) overload
RS485 terminating resistor	use external resistor (120 Ohm)
Power supply	
Alternating current	permissible range AC 16...28 V
Direct current	permissible range DC 10...32 V
Consumption	<50mA (typically <20 mA / 24 V)

Recommended fuse	fuse T 100 mA
Galvanic Isolation	
From the meter	yes
From the RS485 network	no

9.9 Modbus module (WZU-485E-MOD)

WZU-485E-MOD is an add-on communication module for the following types of meters: T550 (UH50...) (firmware 5.15 and higher) and T550 (UC50...). The module is intended and preconfigured for data transmission using the Modbus RTU protocol on RS485.

General information

Communication protocol	Modbus RTU
Modbus address range	1 – 247
Transmission rate	2400 / 4800 / 9600 / 19200 bps
Communication address	M-Bus primary address of T550 (Loop 4: RP 1 127)
Data refreshing	Stand-by mode: 60 min In operation: After every data request, up to 10s
Parity	Even / odd / none
Number of stop-bits	1

Default settings

Transmission rate	9600 bps
Modbus Parity	even
Communication address	0 (meter default; must be changed)

RS485 information

HW network connection	RS485: A+, B-, GND communication signal inputs (A, B) are protected against short-term (pulse) overload
RS485 terminating resistor	use external resistor (120 Ohm)

Power supply

Alternating current	permissible range AC 16...28 V
Direct current	permissible range DC 10...32 V
Consumption	<50mA (typically <20 mA / 24 V)
Recommended fuse	fuse T 100 mA
Galvanic Isolation	
From the meter	yes
From the RS485 network	no

10 Tariff control (optional)



Note: The tariffs can only be parameterized using the service software.



Note: The summation of quantity of energy and volume in the standard registers is performed independently of the tariff situation.

The following options are available for tariff control:

Threshold value tariff (tariffs T2, T3, T4, T5, T6)

The threshold value tariff can be derived from

- the flowrate (tariff T2),
- the power (tariff T3),
- the temperature cold side (tariff T4),
- the temperature warm side (tariff T5) or
- the temperature difference (tariff T6).

The total heat quantity and the total volume are always summed. But the heat quantity or the volume can also be acquired dependently from threshold value in up to 3 tariff register.

Each tariff threshold is assigned its own tariff register.

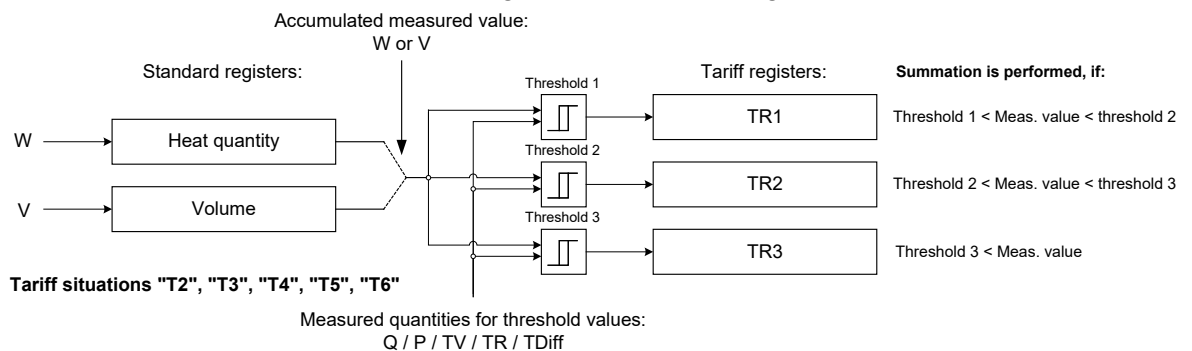

Summation in the relevant tariff register is only performed if the relevant threshold is exceeded.

- Threshold 1 exceeded: Summation in tariff register 1
- Thresholds 1 and 2 exceeded: Summation in tariff register 2
- Thresholds 1, 2 and 3 exceeded: Summation in tariff register 3

Supplied quantity of energy / Adjusted Energy (tariff T7)

In tariff register 1, a quantity of energy is summated that is calculated from the temperature warm side (instead of from the temperature difference). The function “Adjusted Energy” (from FW 5.24) calculates the energy from the reference temperature, the temperature of the warm side and adds it up in tariff register 1.

Returned quantity of energy (tariff T8)

In tariff register 1, a quantity of energy is summated that is calculated from the temperature cold side (instead of from the temperature difference).

Heating/Cooling meter (tariff T9)

In tariff register 1, the measured quantity of cold; in tariff register 2, the measured quantity of heat is summated. In both cases a threshold can be defined via the temperature hot side (“cold threshold”, “heat threshold”).

- Temperature above “heat threshold” and temperature difference $> +0.2$ K → quantity of heat is acquired
- Temperature below “cold threshold” and temperature difference < -0.2 K → quantity of cold is acquired

Tariff control via timer switch (tariff T10)

For tariff control, one switch-off time and one switch-on time per day can be defined. At the switch-on time, summation of the quantity of energy or volume is started in tariff register 1; at the switch-off time, it is ended.

Tariff control via M-Bus (tariff T11)

In tariff registers 1, 2 and 3, either the quantity of energy or the volume can be summated. With the relevant M-bus command, one of the 3 tariffs can be activated, or all tariffs can be deactivated.

Surcharge quantity tariff by means of return temperature (tariff T12)

The quantity of energy is summated depending on the temperature cold side in tariff registers 1 or 2.

The summated quantity of energy is calculated from the difference of the temperature cold side from the defined return temperature threshold (instead of from the temperature difference).

- Above return threshold: T1 is summated
- Below return threshold: T2 is summated

Display of the tariff situation on the LCD

The current tariff status is shown in the user loop “LOOP 0” together with the quantity of energy or the volume.

No tariff status is shown for tariffs T7 and T8.

For tariffs T2, T3, T4, T5, T6, T10, T11 and T12

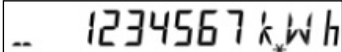
 no tariff register active

 tariff register 1 active

 tariff register 2 active

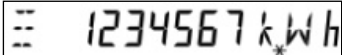
 tariff register 3 active

For tariffs T9 (heating/cooling meter)

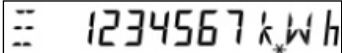
 no tariff register active

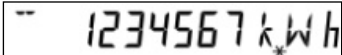
 tariff register 1 active

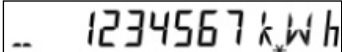
 tariff register 2 active

The type of tariff and the associated parameters are displayed in service loop “LOOP 4”.

T2 0,000 m ³ /h	for T2, T3, T4, T5, T6 in 2-sec. cycles with threshold value 1/2/3
' 0,000 m ³ /h	
T7 0 °C	for T7
T8 0 °C	for T8
T9c 18 °C	for T9;
T9h 45 °C	in 2-sec. cycles
T 10 -----	
01 00,00 0	for T10; switching times in 2-sec. cycles
02 12,00 1	
T 11 -----	for T11
T 12 50 °C	for T12

The contents of the tariff registers are displayed in the user loop after the quantity of energy.

For tariffs T2, T3, T4, T5, T6, T10, T11 and T12

T' 1234567 kWh	tariff register 1
T'' 1234567 kWh	tariff register 2
T''' 1234567 kWh	tariff register 3 (not for T12)
0H 1234567 kWh	for tariff T7
RH 1234567 kWh	for tariff T8
HE 1234567 kWh	for tariff T9
C0 1234567 kWh	

11 Error messages

The meter continuously runs a self-diagnosis and can thus recognize and display various installation or meter error messages.

Error code	Error	Service guidelines
FL neG	Incorrect flow direction	Check flow or installation direction; correct if necessary
if necessary in exchange with:		
DIFF nEG	Negative temperature difference	Check installation point of the temperature sensors; exchange if necessary
if necessary in exchange with:		
F0	No flow can be measured	Air in the measurement unit/pipe; bleed air from line (delivery condition)
F1	Interruption in the hot side temperature sensor	Check hot side temperature sensors; replace if necessary
F2	Interruption in the cold side temperature sensor	Check cold side temperature sensors; replace if necessary
F3	Electronics for temperature evaluation defective	Exchange the meter
F4	Problem with the power supply; Battery flat;	Check connection; Change battery
F5	Short-circuit hot side temperature sensor	Check hot side temperature sensors; replace if necessary
F6	Short-circuit cold side temperature sensor	Check cold side temperature sensors; replace if necessary
F7	Fault in internal memory holding	Exchange the meter
F8	Errors F1, F2, F3, F5 or F6 for longer than 8 hours, recognition of attempts to manipulate. No further measurements are carried out.	Measure dependent on error code. Error message F8 must be reset by service department.
F9	Fault in the electronics	Exchange the meter



Note: Reset the message F8 in the parameterization mode manually or with the service software. All other error messages are deleted automatically once the error has been rectified.

12 Log functions

In the internal logbook, metrologically relevant events (errors, states, actions) are stored in chronological order with their time of occurrence. The events acquired are predefined. The data of the logbook cannot be deleted.

Each event is stored in a separate 4-level shift register; the overflows are transferred to a 25-level circulating buffer. Therefore, at least the last 4 times can be traced for each event.

In a monthly register, the error states are stored for the current month and for the past 18 months (without time stamp).

Ser. No.	Description
1	F0 = Air in measuring tube
2	F1 = Interruption temperature sensor hot side
3	F2 = Interruption temperature sensor cold side
4	F3 = Error temperature electronics
5	F5 = Short-circuit temperature sensor hot side
6	F6 = Short-circuit temperature sensor cold side
7	F8 = Temperature sensor error > 8 hours
8	F9 = ASIC error
9	Above max. temperature in the volume measuring unit
10	Below min. temperature in the volume measuring unit
11	Max. flowrate qs was exceeded
12	Soiling pre-warning
13	Line voltage off
14	CRC error occurred
15	Adjustment values parameterized
16	F7-(EEPROM) pre-warning
17	Reset made
18	Date / time parameterized
19	Yearly set day parameterized
20	Monthly set das parameterized

21	Master reset performed
22	All times deleted
23	Missing time deleted
24	Maxima deleted



Note: Read-out is performed via the optical interface with the service software.

13 Data logger (optional)

The data logger permits the archiving of data that the user can select from a predefined set of values. The data logger contains four archives whose 8 channels can be assigned. The data can be assigned to any of the channels.

Archive	Time base	Storage depth	Averaging time for maximum*)
Hourly archive	1 hour	45 days	1 hour
Daily archive	1 day	65 days	1 hour
Monthly archive	1 month	15 months	1 hour
Yearly archive	1 year	15 years	1 hour / 24 hours

*) For a shorter measuring period than 1 hour, the largest value from the maximum values calculated within one hour applies.



Note: Parameterization and read-out are performed with the service software.



Note: Data transmission is in a manufacturer-specific format.

	Value set for data to be recorded
Meter readings at the end of the period for...	Quantity of energy Tariff register 1, 2, 3 Volume Operating duration*) Fault duration*) Pulse input 1 Pulse input 2
Instantaneous values at the end of the period for...	Power Flowrate Temperature hot side Temperature cold side Temperature difference Error display
Maximum for...	Power Flowrate Temperature hot side Temperature cold side Temperature difference

*) depending on parameter setting: hours or days

14 Additional options

Options:

- Version with data logger
- Heating meter for mounting place hot side
- Operable as flow meter
- Cooling meter 6/12 °C
- Combined heat/cold meter
- Length of the control cable between measurement tube and electronic unit up to 5 m
- Electronic unit for connecting temperature sensors in four wire technique

15 Order codes (type designation)

Mandatory data for the order designation (label plate data)

Mandatory data for Hardware-dependent features

Type Code:

U H 5 0 - X Y Y X - Y Y X X - Y

X X - Y X Y X - Y Y X

- 1. Meter type and mounting location
- 2. Nominal flowrate
- 3. Control cable/ type/ electronic unit
- 4. Country/ where used
- 5. Manufacturer's label
- 6. Sensor type and connection method

- 7. Sensor design
- 8. Power Supply
- 9. Communication 1/ module1
- 10. Communication 2/ module 2
- 11. Data logger
- 12. Calibration/ conformity
- 13. Energy unit

Order codes for dial plate data	
1. Type of meter and mounting location	Code
Heating meter for two wire temperature measurement, mounting place cold side	A
Heating meter for two wire temperature measurement, mounting place hot side	B
Combined heat/cold meter for two wire temperature measurement, mounting place cold side (only in connection with temperature sensor Pt500)	C
Flow sensor	D
Cooling meter for two wire temperature measurement, mounting place hot side (only in connection with temperature sensor Pt500)	G
Cooling meter for two wire temperature measurement, mounting place cold side	H
Heating meter for four wire temperature measurement, mounting place cold side	L
Heating meter for four wire temperature measurement, mounting place hot side	M
Combined heat/cold meter for four wire temperature measurement, mounting place cold side (only in connection with temperature sensor Pt500)	N
Cooling meter for four wire temperature measurement, mounting place hot side (only in connection with temperature sensor Pt500)	T
Cooling meter for four wire temperature measurement, mounting place cold side	U
2. Nominal flowrate	Code
Nominal flowrate 0.6 m³/h, length 130 mm, nominal pressure PN16, connection G 1 B	03
Nominal flowrate 0.6 m³/h, length 130 mm, nominal pressure PN25, connection G 1 B	04
Nominal flowrate 0.6 m³/h, length 110 mm, nominal pressure PN16, connection G ¾ B	05
Nominal flowrate 0.6 m³/h, length 110 mm, nominal pressure PN25, connection G ¾ B	06
Nominal flowrate 0.6 m³/h, length 190 mm, nominal pressure PN16, connection G 1 B	07
Nominal flowrate 0.6 m³/h, length 190 mm, nominal pressure PN25, connection flanged DN 20	08
Nominal flowrate 0.6 m³/h, length 190mm, nominal pressure PN25, connection G 1 B	09

Nominal flowrate 1.5 m³/h, length 110 mm, nominal pressure PN16, connection G ¾ B	21
Nominal flowrate 1.5 m³/h, length 110 mm, nominal pressure PN25, connection G ¾ B	22
Nominal flowrate 1.5 m³/h, length 190 mm, nominal pressure PN16, connection G 1 B	23
Nominal flowrate 1.5 m³/h, length 190 mm, nominal pressure PN25, connection flanged DN 20	24
Nominal flowrate 1.5 m³/h, length 190 mm, nominal pressure PN25, connection G 1 B	25
Nominal flowrate 1.5 m³/h, length 130 mm, nominal pressure PN16, connection G 1	26
Nominal flowrate 1.5 m³/h, length 130 mm, nominal pressure PN25, connection G 1	27
Nominal flowrate 2.5 m³/h, length 130 mm, nominal pressure PN16, connection G 1 B	36
Nominal flowrate 2.5 m³/h, length 130 mm, nominal pressure PN25, connection G 1 B	37
Nominal flowrate 2.5 m³/h, length 190 mm, nominal pressure PN16, connection G 1 B	38
Nominal flowrate 2.5 m³/h, length 190 mm, nominal pressure PN25, connection flanged DN 20	39
Nominal flowrate 2.5 m³/h, length 190 mm, nominal pressure PN25, connection G 1 B	40
Nominal flowrate 3.5 m³/h, length 260 mm, nominal pressure PN16, connection G 1 ¼ B	45
Nominal flowrate 3.5 m³/h, length 260 mm, nominal pressure PN25, connection flanged DN 25	46
Nominal flowrate 3.5 m³/h, length 260 mm, nominal pressure PN25, connection G 1 ¼ B	47
Nominal flowrate 6.0 m³/h, length 260 mm, nominal pressure PN16, connection G 1 ¼ B	50
Nominal flowrate 6.0 m³/h, length 260 mm, nominal pressure PN25, connection G 1 ¼ B	51
Nominal flowrate 6.0 m³/h, length 260 mm, nominal pressure PN25, connection flanged DN 25	52
Nominal flowrate 6,0 m³/h, length 150 mm, nominal pressure PN16, connection G 1 ¼ B	55
Nominal flowrate 10 m³/h, length 300 mm, nominal pressure PN16, connection G 2 B	60
Nominal flowrate 10 m³/h, length 300 mm, nominal pressure PN25, connection flanged DN 40	61
Nominal flowrate 10 m³/h, length 300 mm, nominal pressure PN25, connection G 2 B	62

Nominal flowrate 10 m ³ /h, length 200 mm, nominal pressure PN16, connection G 2 B	63
Nominal flowrate 15 m ³ /h, length 270 mm, nominal pressure PN25, connection flanged DN 50	65
Nominal flowrate 15 m ³ /h, length 200 mm, nominal pressure PN25, connection flanged DN 50	69
Nominal flowrate 25 m ³ /h, length 300 mm, nominal pressure PN25, connection flanged DN 65	70
Nominal flowrate 40 m ³ /h, length 300 mm, nominal pressure PN25, connection flanged DN 80	74
Nominal flowrate 60 m ³ /h, length 360 mm, nominal pressure PN16, connection flanged DN 100	82
Nominal flowrate 60 m ³ /h, length 360 mm, nominal pressure PN25, connection flanged DN 100	83
Nominal flowrate 150 m ³ /h, length 500 mm, nominal pressure PN16, connection DN 150	A1
Nominal flowrate 150 m ³ /h, length 500 mm, nominal pressure PN25, connection DN 150	A2
Measurement insert: Nominal flowrate 150 m ³ /h, length 500 mm, nominal pressure PN16, connection DN 150	A3
Measurement insert: Nominal flowrate 150 m ³ /h, length 500 mm, nominal pressure PN25, connection DN 150	A4
3. Control cable / type / electronic unit	Code
Split version with 1.5 m control cable	C
Split version with 3.0 m control cable	D
Split version with 5.0 m control cable	E
Split version with 1.5 m control cable, control cable removable	P
Split version with 3.0 m control cable, control cable removable	Q
Split version with 5.0 m control cable, control cable removable	R
4. County / where used	Code
Dial plate for Middle East (English)	AE
Dial plate for Austria (German)	AT
Dial plate for Austria (German)	AU
Dial plate for Bosnia-Herzegovina (Croatian)	BA
Dial plate for Belgium (French/Flemish)	BE
Dial plate for Bulgaria (Bulgarian)	BG
Dial plate for Belarus (Russian)	BY
Dial plate for Switzerland (German/French)	CH
Dial plate for China (Chinese)	CN
Dial plate for Czech Republic (Czech)	CZ
Dial plate for Germany (German)	DE
Dial plate for Denmark (Danish)	DK
Dial plate for Estonia (Estonian)	EE
Dial plate English neutral	EN
Dial plate for Spain (Spanish)	ES
Dial plate for Finland (Finnish)	FI
Dial plate for France (French)	FR
Dial plate for Great Britain (English)	GB
Dial plate for Greece (English)	GR
Dial plate for Croatia (Croatian)	HR
Dial plate for Hungary (Hungarian)	HU
Dial plate for Iceland (Icelandic)	IS
Dial plate for Italy (Italian)	IT
Dial plate for Japan (Japanese)	JP
Dial plate for Luxembourg (German/French)	LU
Dial plate for Moldova (Romanian)	MD
Dial plate for Montenegro (Serbian)	ME
Dial plate for Macedonia (Macedonian)	MK
Dial plate for Mongolia (Mongolian)	MN
Dial plate for The Netherlands (Dutch)	NL
Dial plate for Norway (Norwegian)	NO
Dial plate for Poland (Polish)	PL
Dial plate for Romania (Romanian)	RO
Dial plate for Serbia (Serbian)	RS

Dial plate for Russia (Russian)	RU
Dial plate for Sweden (Swedish)	SE
Dial plate for Slovak Republic (Slovakian)	SK
Dial plate for Southern Tyrol (German)	I2
Dial plate for Ukraine (Ukrainian)	UA
5. Manufacturer's label	Code
Logo Landis+Gyr	00
Other labels on request	xx
6. Sensor type and method of connection	Code
Flow sensor (without temperature sensors)	0
Sensor Pt100, removable, not mounted in the tube	A
Sensor Pt100, removable, mounted in the tube	B
Sensor Pt100, removable, mounting in the tube as an option	C
Sensor Pt500, removable, not mounted in the tube	E
Sensor Pt500, removable, mounted in the tube	F
Sensor Pt500, removable, mounting in the tube as an option	G
Sensor Pt500, not removable, not mounted in the tube	N
Sensor Pt500, not removable, mounted in the tube	P
Sensor Pt500, not removable, mounting in the tube as an option	R
Hardware-dependent features	
7. Sensor type	Code
Without temperature sensors	00
Type DS, 25 bar/150°C/ M10x1 / length 27.5 mm, cable length 1.5 m	0B
Type DS, 25 bar/150°C/ M10x1 / length 27.5 mm, cable length 2.5 m	0C
Type DS, 25 bar/150°C/ M10x1 / length 38 mm, cable length 1.5 m (only Pt500)	0D
Type DS, 25 bar/150°C/ M10x1 / length 38 mm, cable length 2.5 m (only Pt500)	0E
Type PS, 16 bar/150°C/ Ø5,2x45mm, cable length 1.5 m	0H
Type PS, 16 bar/150°C/ Ø5,2x45mm, cable length 5 m	0J
Type PL, 25 bar/180°C/ Ø6x100mm, cable length 2 m	0M
Type PL, 25 bar/180°C/ Ø6x100mm, cable length 5 m (only Pt500)	0N
Type PL, 25 bar/180°C/ Ø6x150mm, cable length 2 m	0P
Type U, 25 bar/150°C/ Ø6x60 mm, cable length 3 m	0S
Type U, 25 bar/150°C/ Ø6x60 mm, cable length 5 m	0T
Type U, 25 bar/150°C/ Ø6x60 mm, cable length 10 m	0U
Type PL, 25 bar/180°C/ Ø6x150mm, cable length 5 m (only Pt500)	0Q
8. Power supply	Code
Without power supply	0
Standard battery for 6 years (2xAA cells)	A
Battery for 6 years for all applications (D-cell)	B
Battery for 11 years (C-cell)	C
Battery for 11 years (D-cell)	E
Battery for 16 years (D-cell)	F
Power supply 24 V AC/DC with plug	M
Power supply 100 - 240 V AC with 1.5 m cable	N
Power supply 100 - 240 V AC with 5 m cable	P
9. Communication module 1	Code
No module	0
Analog module	A
M-Bus module G4	B
M-Bus module G4-MI with 2 pulse inputs	N
Pulse module standard	P
10. Communication module 2	Code
No module	0
Analog module	A

M-Bus module G4	B
Wireless M-Bus module with internal antenna*)	E
Wireless M-Bus module with SMA connection for external antenna*)	F
Pulse module	P
NB-IoT module	1
NB-IoT module with SIM	2
NB-IoT module with SIM provided by customer	3
LoRaWAN® module with internal antenna **)	4
LoRaWAN® module with external antenna**)	5
11. Data logger	Code
Without data logger	0
Data logger with 8 channels	8
12. Calibration / conformity	Code
Certified acc. to national regulations	CL
Compliant to MID class 2	M2
Compliant to MID class 3	M3
Compliant with CEN 1434, class 2	T2
Compliant with CEN 1434, class 3	T3
Compliant acc. to national regulations	TL
13. Energy unit	Code
Display: kWh (until qp 10)	A
Display: MWh with 3 decimal places (as of qp 15 with 2 decimal places; as of qp 150 with 1 decimal place)	B
Display: MJ (until qp 2.5)	C
Display: GJ with 3 decimal places (as of qp 3.5 with 2 decimal places; as of qp 40 with 1 decimal place)	D

Display: kWh (until qp 10), flashing	G
Display: MWh with 3 decimal places (as of qp 15 with 2 decimal places), flashing	H
Display: GJ with 3 decimal places (as of qp 6 with 2 decimal places), flashing	K
Only for flow sensor: Display: m ³ with 2 decimal places (as of qp 25 with 1 decimal place)	V
Further features	
Measurement dynamics	Code
Dynamic range 1:100	C
Other ranges on request	

*) Additional ordering information needed (see page 43)

**) Additional ordering information needed (see page 44)

16 Additional ordering information on radio module 868 MHz (wireless M-Bus EN13757-4, OMS v2.0/ OMS v4.1.2)

For OMS v2.0, radio mode T1, security profile A (encryption mode 5)

For OMS v4.1.2 (BSI), radio mode T1, security profile B (encryption mode 7) or radio mode C1

Necessary additional ordering information:

Wireless M-Bus module 868 MHz with integrated / external antenna:

UH50-XXX0-Y 00-YX**EX**-YYX

UH50-XXX0-Y 00-YX**FX**-YYX

Description	OMS
1. Protocol type	Code
OMS 2.0 / wireless M-Bus T1	2
OMS 4.1.2 / wireless M-Bus T1 (BSI) *	7
OMS 4.1.2 / wireless M-Bus C1	8
2. Sending interval	Code
Sending interval 15 minutes	0
Sending interval 1 minutes	3
Sending interval 16 seconds	5
Sending interval 20 seconds	8
Sending interval 12 seconds	9
3. Encryption	Code
None (with age information)	00
None (without age information)	10
Security profile A (without age information), encryption mode 5	01
Security profile A (with age information), encryption mode 5	11
Security profile A (without age information)**, encryption mode 7	02
Security profile A (with age information)***, encryption mode 7	12
4. Data telegram	Code
Telegram radio standard	P600
Telegram mobile radio	P601
Telegram mobile radio with tariffs	P602

More data telegrams on request.

Please find the information about the lifetime of battery in chapter 8.

^{*)} only for OMS 2.0

^{**)} Recommended for security profile B (02; 12) with encryption

^{***)} Especially when connected to a smart meter gateway (Germany). At the time of transmission, it indicates the elapsed time since the radio module retrieved data from the processor.

Ordering example:

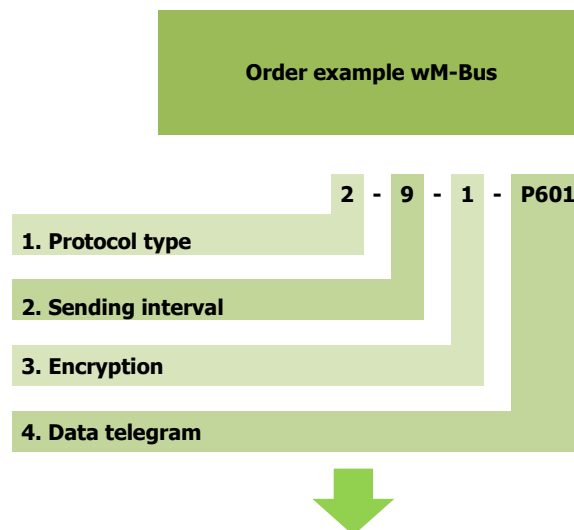

UH50-XXX0-Y 00-YX**EX**-YYX + **2-8-01-P601**

E = wireless M-Bus module with antenna

2 = OMS v2.0, radio mode T1

8 = Sending interval 20 seconds (mobile radio)

01 = Security profile A (without age information), encryption mode 5

P601 = Telegram mobile radio

- Current energy
- Current volume
- Energy on monthly set day
- Volume on monthly set day
- Monthly set day
- Energy at yearly set day
- Yearly set day
- Error (manufacturer specific)
- Current time stamp (type I)

OMS:

Open Metering System Specification: Industry standard of a community of interest of companies and associations. It develops open and vendor independent specifications for communication interfaces and basic requirements for meters - <http://oms-group.org>.

Defines requirements in addition to standard EN13757-4.

17 Additional order information for LoRaWAN® module

If a configuration different from the factory setting (*) is required.

More details about the function in the Elvaco User Manual module CMI4110!

Necessary additional information on the order with LoRaWAN module int. / ext. antenna

UH50-YYY0-Y 00-YX**4**X-YYX

UH50-YYY0-Y 00-YX**5**X-YYX

Description	LoRa
1. POWERMODE	Code
Not active (radio off) *	00
Active (radio on)	01
2. MESSAGEFORM (Telegram content)	Code
Standard *	00
Compact	01
JSON	02
Scheduled – daily redundant	03
Scheduled – extended	04
Scheduled – extended + (Tariff)	05
Compact Tariff	06
3. ECOMODE	Code
Ecomode (power saving) off	00
Ecomode (power saving) on *	01
4. TXINTERVALL	
Transmission interval in minutes	XXXX
(Input: 15* .. 1440)	
5. MAXDAILYTRANS	Code
Limit how many times per day maximum is sent.	XX
Input: 1, 2, 3, 4, 6, 8, 9, 12, 24, 48, 96* times per day	
6. CONFIGLOCK (Configuration lock)	Code
Locked	00
Unlocked*	01
7. Activation (Connection type)	
ABP	00
OTAA *	01
8. JoinEUI (ID des Join Servers)	
0000000000000000 *	
16-digit number (hexadecimal)	

When ECOMODE is off, the telegrams are sent according to **MAXDAILYTRANS**. No information can be provided about the battery lifetime!

Battery life 6 years: ECOMODE off

Battery life 11 years: ECOMODE on

For more details on battery life, see Chap.8.

Ordering example:

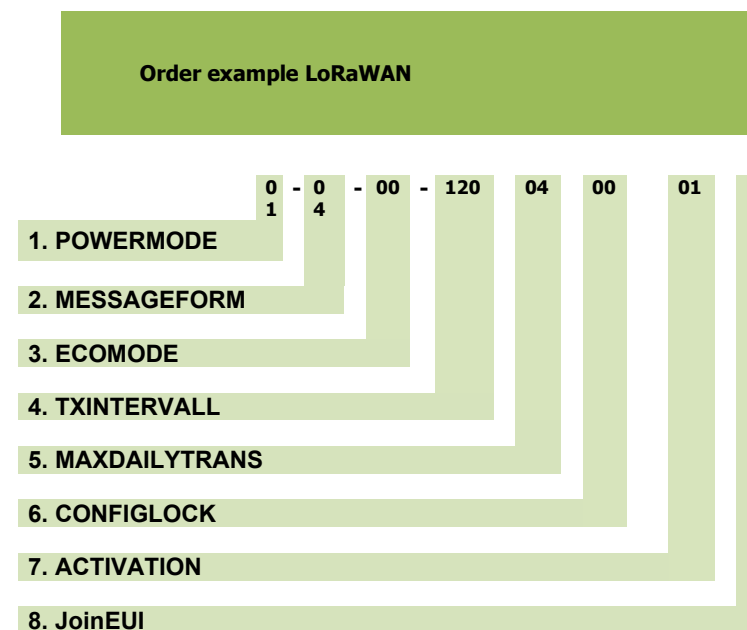

UH50-YYY0-Y 00-YX**4**X-YYX + **00-04-00-60-24-00-01-1234567891234567**

01 = Active (radio on)

04 = Message format "Scheduled – extended"

00 = Ecomode (power saving) off

00 60 = Transmission interval 60 minutes

24 = Send max. 24 times per day

00 = Module locked, only for registered user (in the OTC Web Service App from Elvaco)

01 = OTAA

1234567891234567 – Customized JoinEUI

LoRaWAN®:

The LoRa Alliance® is an open, non-profit association with the mission to support and promote the global adoption of the LoRaWAN® standard, the leading LPWAN

18 Pressure loss

Nominal flowrate qp	Overall length	Connection	Pressure loss at qp	Kv-Factor at Δp 1 bar	Graph in di- agram
m ³ /h	mm		mbar	m ³ /h	
0.6	110, 130, 190	G 3/4, G 1, DN20	150	1.5	A
1.5	130, 190	G 1, DN20	160	3.8	B
1.5	110	G 3/4	170	3.9	C
2.5	190	G 1, DN20	210	5.3	D
2.5	130	G 1	200	5.6	E
3.5	260	G 1 1/4, DN25	55	15	G
6	150	G 1 1/4	190	14	F
6	260	G 1 1/4, DN25	140	16	H
10	200, 300	G 2, DN40	130	28	I
10	300	G 2	110	30	J
15	270	DN50	110	45	K
15	200	DN50	95	49	L
25	300	DN65	105	77	M
40	300	DN80	160	100	N
60	360	DN100	115	177	O
150	500	DN150	120	433	P

The indicated pressure loss of a flow sensor is at the nominal flowrate qp.

Using the Kv-Factor, which defines the flow rate at a pressure loss of 1 bar, the pressure loss at any given flow rate can be calculated:

$$\Delta p = 1 \text{ bar} \times \left(\frac{Q}{K_v} \right)^2$$

Δp = pressure loss in bar

Q = flowrate in m³/h

K_v = K_v – Factor at $\Delta p = 1$ bar

Alternatively, the value can be taken from the diagram.

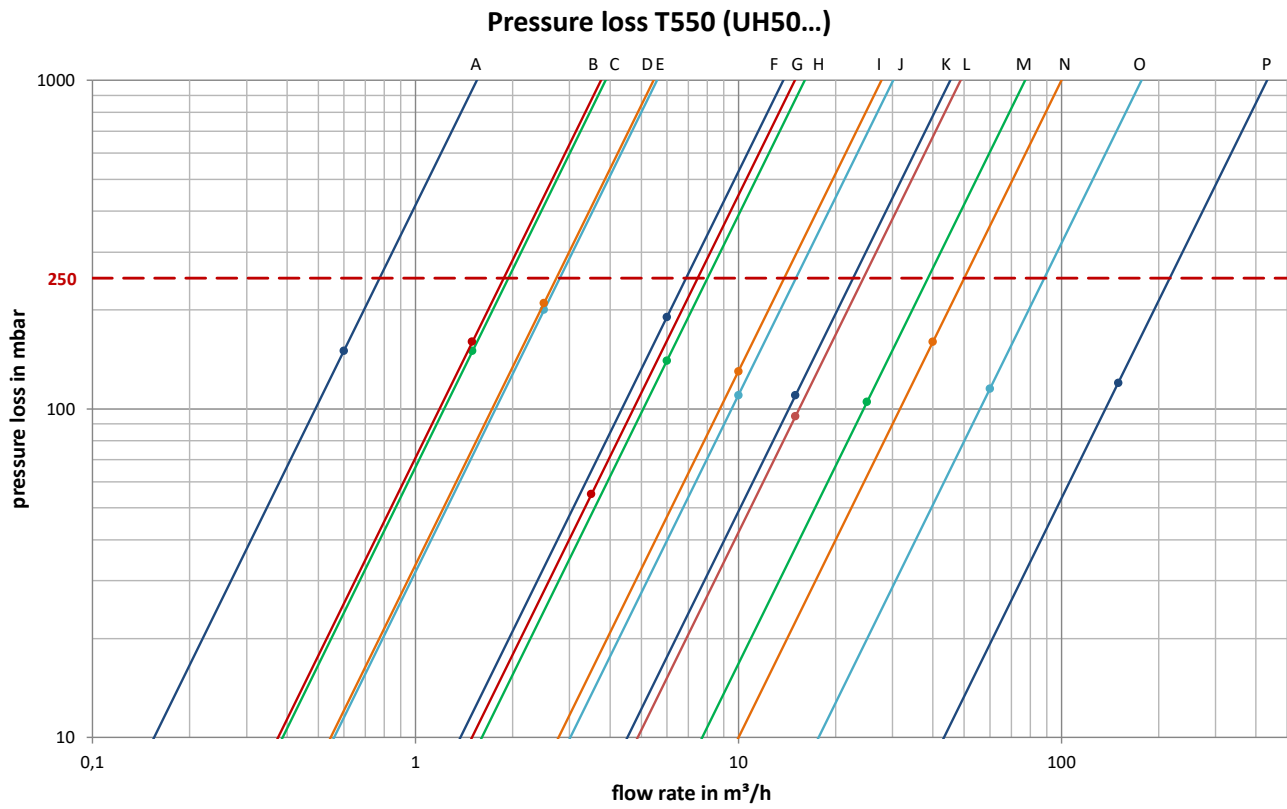

Landis+Gyr GmbH
Humboldtstrasse 64
90459 Nürnberg
Germany
