



Application

The W270 is a modern ultrasonic cold or hot water meter with a lightweight, lead-free composite measuring tube, designed to ensure reliable and reproducible measurements of hot and cold water consumption.

Key Facts

- Ultrasonic measurement - precise, durable
- Easy to use and to install
- Data logger and Logbook
- NFC interface
- wM-Bus, LoRaWAN® or NB-IoT interface
- Easy system integration through certified interfaces
- 15 years of battery lifetime with intelligent battery management

Technical Data

Metrology		Wetted surfaces	
Measuring accuracy	Class 2 (OIML R49)		PPS GF30, PA GF40 Stainless steel
Dynamic range	R250, R160 (Max. R400)	Environmental conditions	
Temperature class	T50 (cold water) T70 (warm water)	Environment class	O (OIML R49) for outdoor installation
Measuring interval	1 Hz	Mechanical class	M1 (MID)
Approvals		Electromagnetical class	E1 (MID)
Metrological	MID, NMI	Ingress Protection	IP68
Hygienic	DVGW, WRAS, ACS, ICIM	Max. height	2000 m above sea level
Others	Australian Water Mark, RCM	Operating temperature	-10 ... 65°C (inside housing)
Data storage		Storage temperature	-20 ... 70 °C (inside housing)
Logbook	Yes: Tracking of 41 events (type, timestamp)	UV protection	
Datalogger	Yes	stabilized	
Datalogger data	Set of up to 9 values	Power supply	
Datalogger depth	15 years 72 months 400 days 744 hours	Power supply	1x D cell lithium battery (5g lithium)
Installation		Battery lifetime	15 years + 2 year in storage mode
Pipe size	DN15, DN20	Display	
Nominal flow	2.5 m³/h, 4 m³/h	Resolution	Volume: 0.001 m³
Pressure class	MAP 16 (16 bar)	Digits	Volume: 9 (6.3) Flow: 5
Orientation	V/H (any orientation)	Information	
Strainer	Yes	Volume, flow, alarms, flow direction, battery status, communication status, signal strength	
Non return valve	Yes (optional)	Other	
		App support	Yes (service app, consumer app)
		Data security	X.509 certificate based access protection



Technical Data

Nominal flow Q3	2.5	2.5	4	2.5	4	[m³/h]
Overall length	110	130	130	190	190	[mm]
Connection	G ¾	G1	G 1	G1	G 1	
Nominal diameter	DN15	DN20	DN20	DN20	DN20	
Maximum flowrate Q4	3.125	3.125	5	3.125	5	[m³/h]
Minimum flowrate Q1 @ R250	10	10	16	10	16	[l/h]
Response threshold (variable)	2	2	4	2	4	[l/h]
Overflow	5	5	8	5	8	[m³/h]
Q3/Q1 max	R400, R250*	R250	R400	R250	R400, R250*	
Pressure loss class	400	400	630	200	630	[mbar]
Pressure loss	353	357	408	159	391	[mbar]
Weight	280	290	290	310	310	[g]

* T70

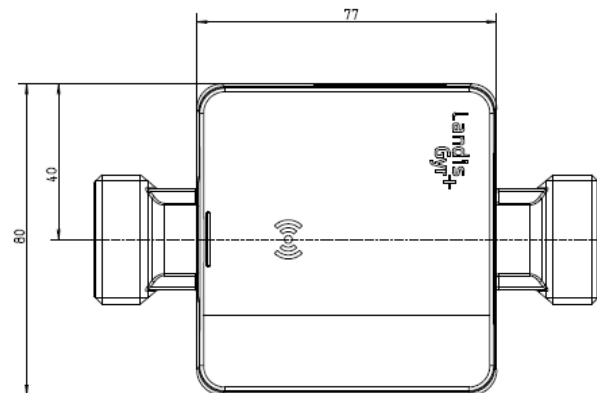
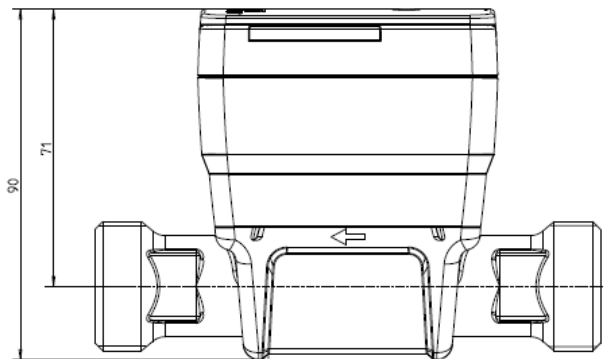



Communication (LoRa or wM-Bus or NB-IoT)

RF interface (LoRa® and wM-Bus switchable)	
LoRa®	
Version	1.0.3
Frequency band	868 MHz
Class	A (bidirectional)
Activation	OTA or ABP
Payload format	M-Bus
Transmission interval	8h, 12h, 24h
Automatic commissioning	Yes
Downlink parameterisation	Yes
wM-Bus	
Standard	Open Metering System Specification OMS (Version 4) EN 13757-4; Mode T1, C1
Frequency band	868 MHz
Transmission power	10 dBm
Range	
- Free field	Up to 400 m
Battery lifetime	Up to 15 a
Sending interval	
- Mobile data reading	30 Seconds
- Stationary data reading	15 Minutes
- User defined data reading	Acc. to telegram length 12 - 900 Seconds
Data telegram	8 predefined data telegrams User defined data telegram with Service Software

NB-IoT	
Standard	NB1 & NB2
Carriers	L+G (Vodafone), others on request
Protocol	OMA LwM2M
Battery lifetime	15 a (@daily transmissions)
Over the air updates	Yes (whole meter firmware)
3GPP	Version 13, 14
Transmission intervals	8h, 12h, 24h
Automatic commissioning	Yes
Downlink parameterisation	Yes
Special functions	Instantaneous alarm transmission Queuing (resume failed transmissions) Downlink parameterisation Dynamic data logger transmissions
Frequency bands	3 (1805-1880 MHz, 5 (869-894 MHz), 8 (925-960 MHz), 20 (791-821 MHz), on request: 28 (758-803MHz)